

## Driven by Technology

AC Drives



AC MultiDrives



MV Drives



Single-Axis Servos



Multi-Axes Servos



Robotics & Motion Controllers



PLCs & HMIs



CNC Machine Tool Solutions



Electric Vehicle Inverters



## IS620 Series - Single Axis Servo

For General Purpose Applications

### INOVANCE

Forward, Always Progressing

#### International Offices

📍 **Hong Kong SAR (export office)**

Tel: +852 2751 6080  
info@inova-automation.com

📍 **South Korea-Seoul**

Tel: +82 (0) 10 7428 5732  
info@inova-automation.com

📍 **India**

Head Office Chennai  
Tel: +91 (0) 44 4380 0201  
Ahmedabad  
Tel: +91 (0) 79 4003 4274  
Mumbai  
Tel: +91 (0) 22 4971 5883  
Delhi Tel: (to be allotted)  
Sales Network in Kolkata, Bengaluru,  
Coimbatore, Hyderabad, Pune  
info.inovaindia@inova-automation.com

For other country distributors, contact the Hong Kong export office.

📍 **Germany-Stuttgart**

Tel: +49 (0) 7144 8990  
sales@powerautomation.com  
www.powerautomation.com

📍 **Italy-Milano**

Tel: +39 (0) 2268 22318  
info@inova-automation.it

📍 **France-Bordeaux**

Tel: +33 (0) 5594 01050  
pa.france@powerautomation.com

📍 **Turkey-Istanbul**

Tel: +90 (0) 21 6706 1789  
info.turkey@inova-automation.com

📍 **China**

Shenzhen Inovance Technology Co., Ltd.  
Suzhou Inovance Technology Co., Ltd.  
Suzhou Monarch Control Technology Co., Ltd.  
info@inova-automation.com



Inovance Technology  
www.inovance.com



EtherCAT® CANopen  
Pulse/analog input  
Embedded motion



# IS620 Series Servos

High-performance servo system for motion control applications



## IS620 Series Servo Drive - Key Features

### High performance

- High current loop bandwidth > 4 kHz
- High speed loop bandwidth: 1.2 kHz

### Wide range

- Supply voltage
  - Single-phase 220V
  - Three-phase 220V
  - Three-phase 380V

- 0.1 kW to 7.5 kW

### Network compatibility

- Pulse/Analog – IS620P series servo
- EtherCAT – IS620N series servos
- CANopen – IS620P-CO series servo

### Easy to use

- Easy commissioning with keypad
- Fine tune with PC software (InoServoShop)

### Smart tuning

- Inertia auto-tuning (On-line/Off-line)
- Automatic gain tuning
- Adaptive notch filter
- Automatic/Manual damping filter for low frequency resonance

## MS1 Series Servo Motor - Key Features

### High precision

- 20-bit resolution serial incremental encoder
- 23-bit resolution multi-turn absolute encoder

### Reliable operation

- IP67 degree of protection with oil seal (MS1H1/H4)
- Low cogging torque – 1% of rated torque

### Wide selection

- Motor frame – 40, 60, 80, 100, 130, 180
- Rated torques from 0.16 Nm up to 48.0 Nm
- Low and medium inertia selection
- Rated speed 1500 rpm or 3000 rpm

### Powerful performance

- Rated torque 350% (750W or less MS1 motor)

# IS620 Series Highlights

The IS620 series is engineered to achieve new levels of performance and reliability – enabling users to maximize the productivity of their automation systems

## High accuracy - Multi-turn absolute encoder with 23 bit resolution

Proprietary Inovance algorithm

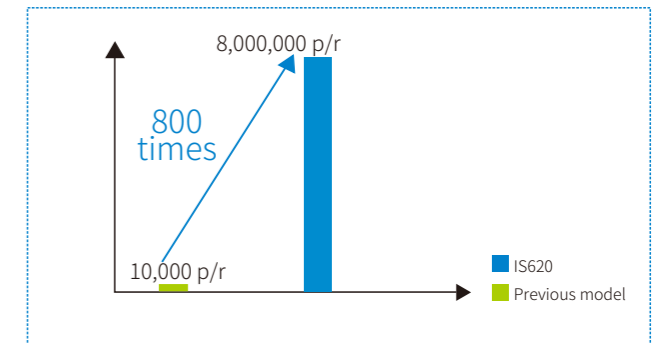
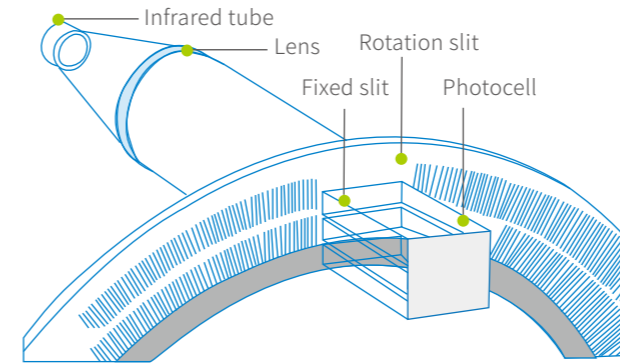

The 23-bit multi-turn absolute encoder, developed by WeTon, an Inovance group subsidiary, has a resolution of 8 million pulses per revolution for extremely precise positioning applications such as industrial robots, machine tools and semiconductor manufacturing machinery.

The system's battery ensures data is backed-up at servo drive power-off and calculates the mechanical absolute position after servo driver power-on. It does not need to repeat the homing operation.

## Smaller footprint, higher performance

The built-in encoder has been developed in house considering size compactness, so the flange is kept the same all along the motor. The MS1H1 and MS1H4 motors are suitable for equipment requiring high torque (maximum torque of 350%).

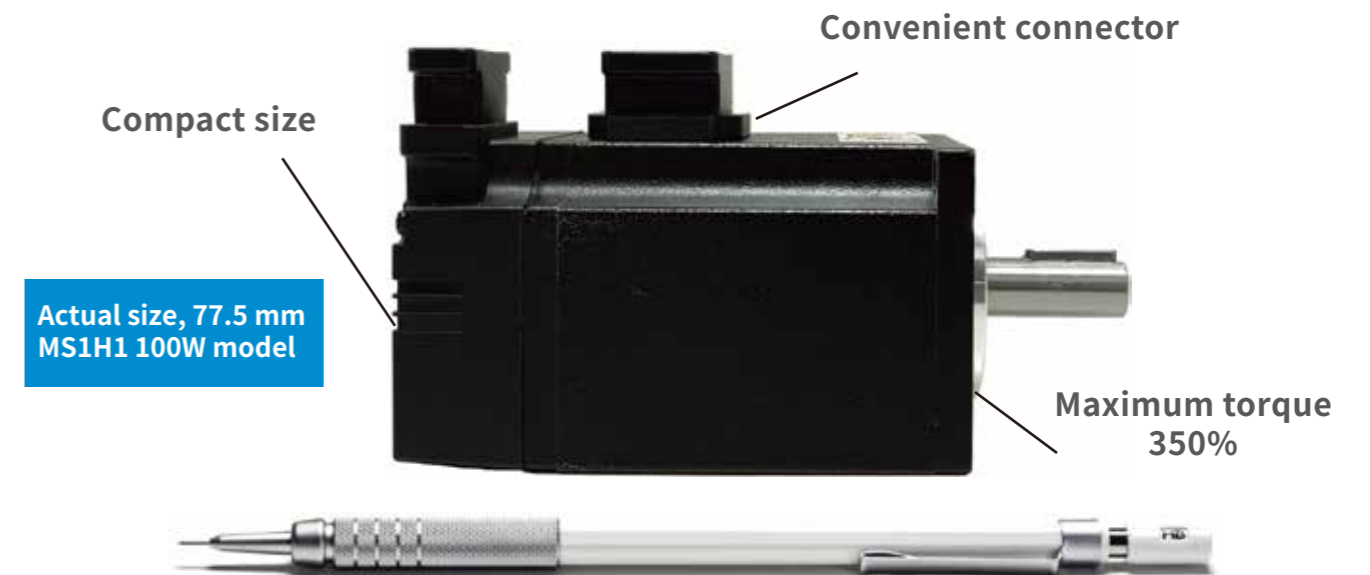

# IS620 Series Highlights

The IS620 series is engineered to achieve new levels of performance and reliability – enabling users to maximize the productivity of their automation systems

## Improved performance – Speed loop bandwidth 1.2 kHz

Speed loop bandwidth is a measure of how fast the motor can respond. High response control based on torque feed forward can reduce the settling time of machines. Settling time of position control is only 5.0 to 6.0 ms.

Shorter settling time, reduced positioning time, higher throughput.

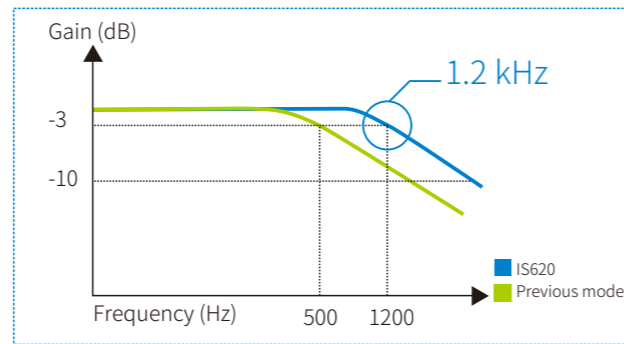

## Smart tuning – Easy commissioning with new tuning function

The machine can be automatically optimized using automatic gain tuning function based on the stiffness level to achieve fast response and stability.

- **Load inertia identification:** on-line and off-line inertia identification.
- **Automatic gain adjustment:** speed loop and position loop gains can be automatically adjusted by setting the stiffness level.
- **Self-adaptive notch filter:** The vibration frequency can be automatically detected and the notch filter can be automatically set.
- **Damping filter:** suppresses vibration from 1 to 100 Hz.

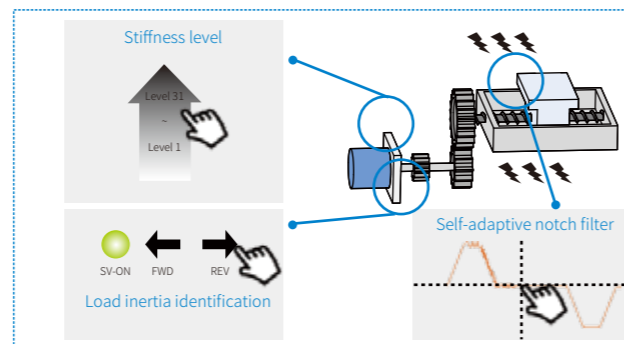

## Wide protocol – Pulse/Analog, EtherCAT, MODBUS, CANopen

The IS620 family of servo drives support a variety of protocols for your system.

- IS620P Servo Drive
  - Pulse/Analog Input;
  - MODBUS RTU: RS232/RS485
  - Internal positioning: Up to 16 positions can be stored. It supports point-to-point positioning using a simple digital input from the controller.
- IS620N Servo Drive
  - EtherCAT: complies with CiA 402 drive profile
- IS620P-CO Servo Drive
  - CANopen: device profile specification for embedded systems

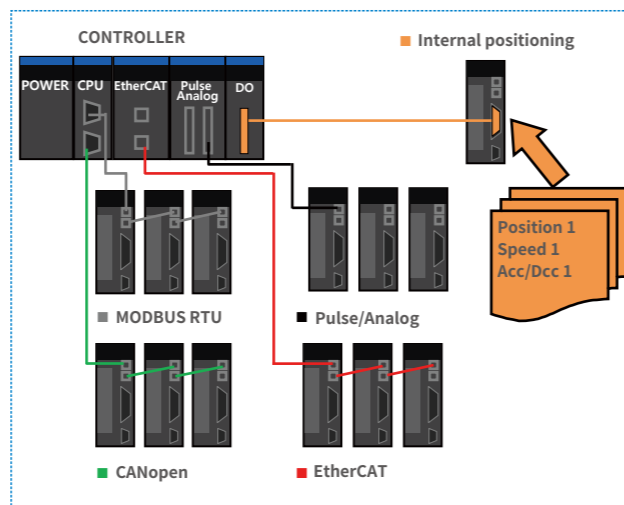

# IS620 Servo Drive Technical Data

Servo drive for position, speed, and torque control via Pulse/Analog, EtherCAT

## IS620 P S 5R5 I - A - INT

① Series IS620 servo drive	④ Rated output current 1R6: 1.6 A ... 021: 21 A 026: 26 A	⑥ Customized function A: 16-bit analog input M: E-cam, gantry sync C: CANlink CO: CANopen CO-EM: Embedded motion
② Product type P: Pulse/Analog N: EtherCAT	⑤ Installation I: Base mount	⑦ Version INT: International
③ Voltage class S: 220 Vac T: 400 Vac		

## Servo drive specifications

Single-phase 220 V

Frame Size	SIZE-A		
Model No.	S1R6	S2R8	S5R5
Rated current (A)	1.6	2.8	5.5
Maximum current (A)	5.8	10.1	16.9
Input voltage	Single-phase 200 to 240 Vac, +10 to -15%, 50/60 Hz		
Internal DBR	No	50Ω / 50W	

Three-phase 220 V

SIZE-A	SIZE-C	
S5R5	S7R6	S012
5.5	7.6	11.6
16.9	17	28
Three-phase 200 to 240 Vac, +10 to -15%, 50/60 Hz		
50Ω / 50W	25Ω / 80W	

Three-phase 380 V

Frame Size	SIZE-C				SIZE-E		
Model No.	T3R5	T5R4	T8R4	T012	T017	T021	T026
Rated current (A)	3.5	5.4	7.4	11.9	16.5	20.8	25.7
Maximum current (A)	8.5	14.0	20.0	24.0	42.0	55.0	65.0
Input voltage	Three-phase 380 to 440 Vac, +10 to -15%, 50/60 Hz						
Internal DBR	100Ω / 80W		50Ω / 80W		40Ω / 100W		

Notes: Internal DBR is built-in regenerative resistor specification.

Models S1R6 and S2R8 are not configured with a built-in regenerative resistor. Use an external regenerative resistor if necessary

## Servo drive dimensions

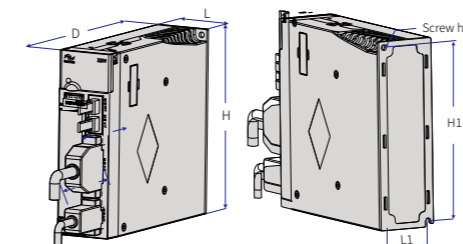

Size	L (mm)	H (mm)	D (mm)	L1 (mm)	H1 (mm)	D1 (mm)	Screw Hole	Tightening Torque (Nm)
A	50	160	173	40	150	75	2-M4	0.6 to 1.2
C	90	160	184	80	150	75	4-M4	0.6 to 1.2
E	100	250	230	90	240	75	4-M4	0.6 to 1.2

# IS620P Servo Drive Configuration

Wiring example of single-phase 220V system

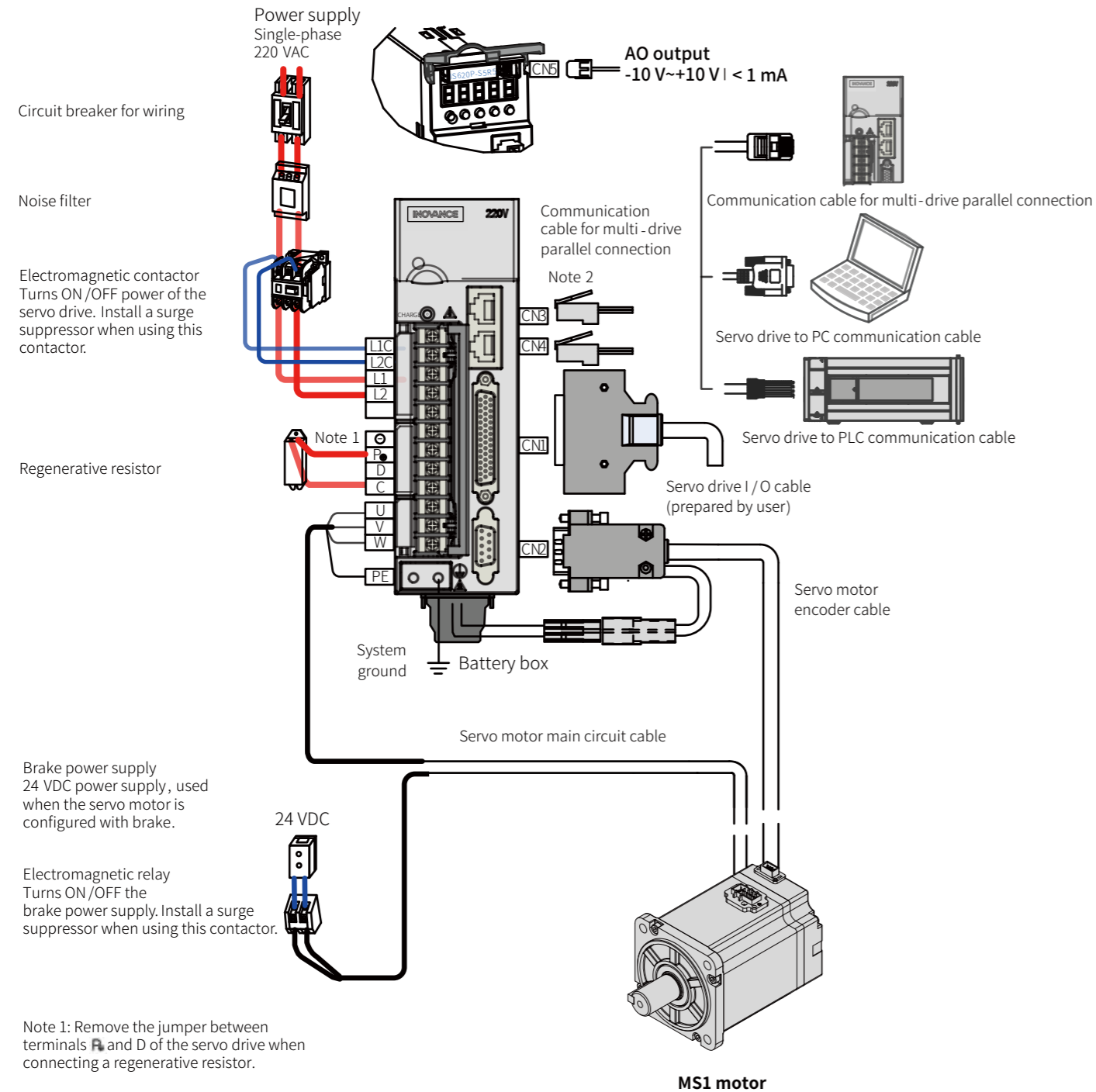

Pulse/Analog

# IS620P Servo Drive Configuration

Wiring example of three-phase 220V/380V system

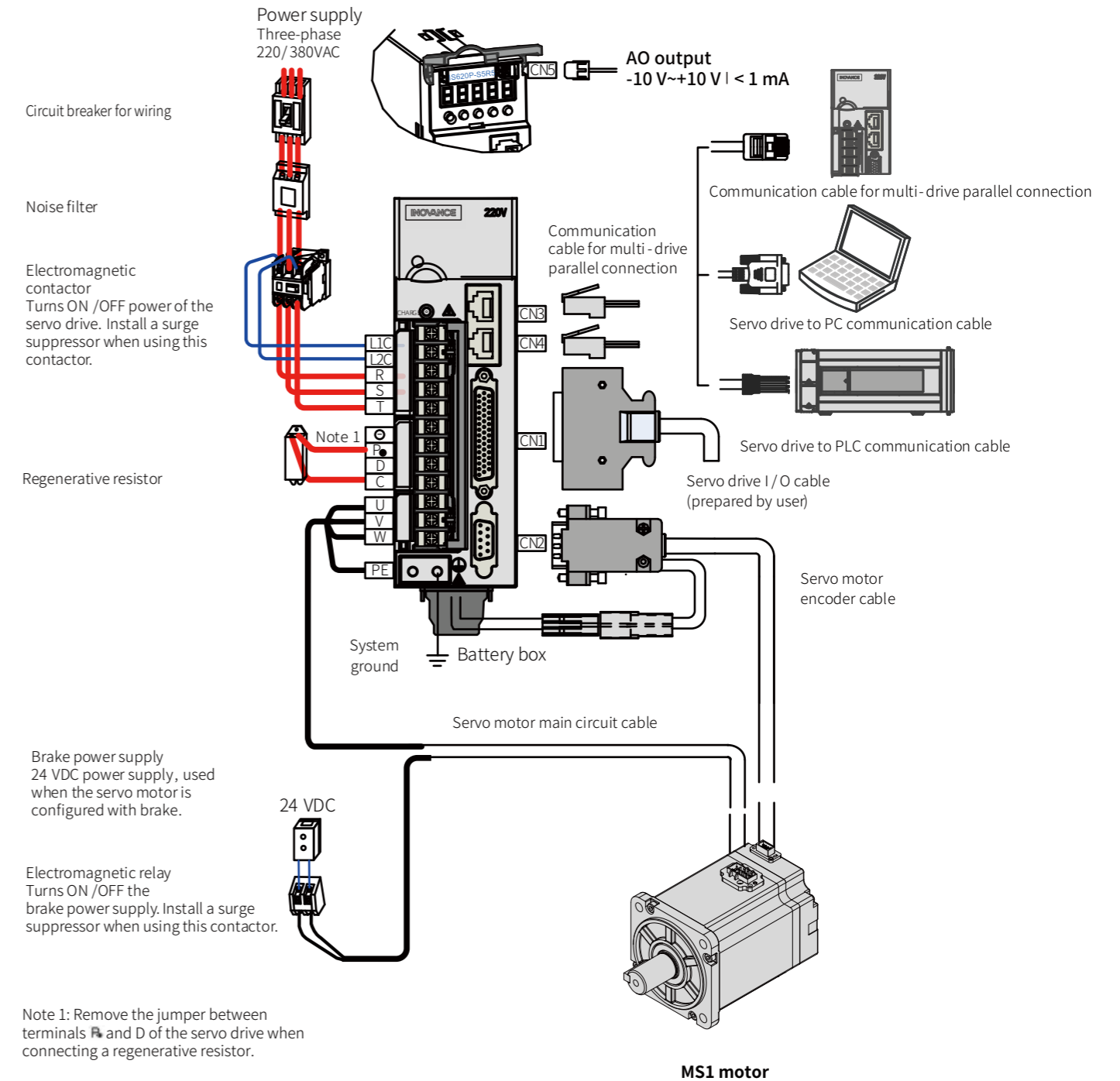

Pulse/Analog

# IS620P Servo Drive Connection Diagram

Standard wiring for pulse train input, analog input

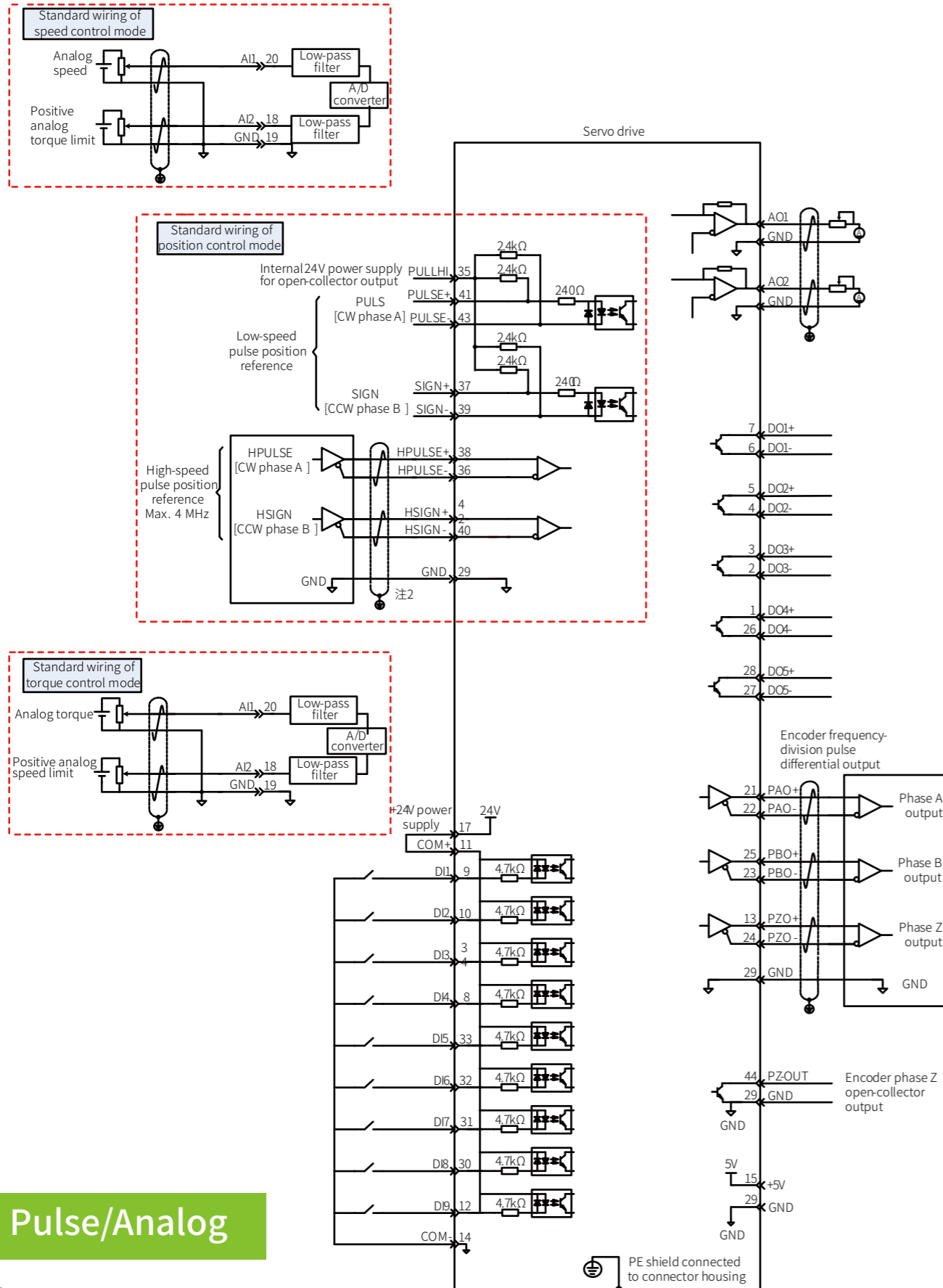

Pulse/Analog

# IS620N Servo Drive Configuration

Wiring example of single-phase 220V system with EtherCAT network

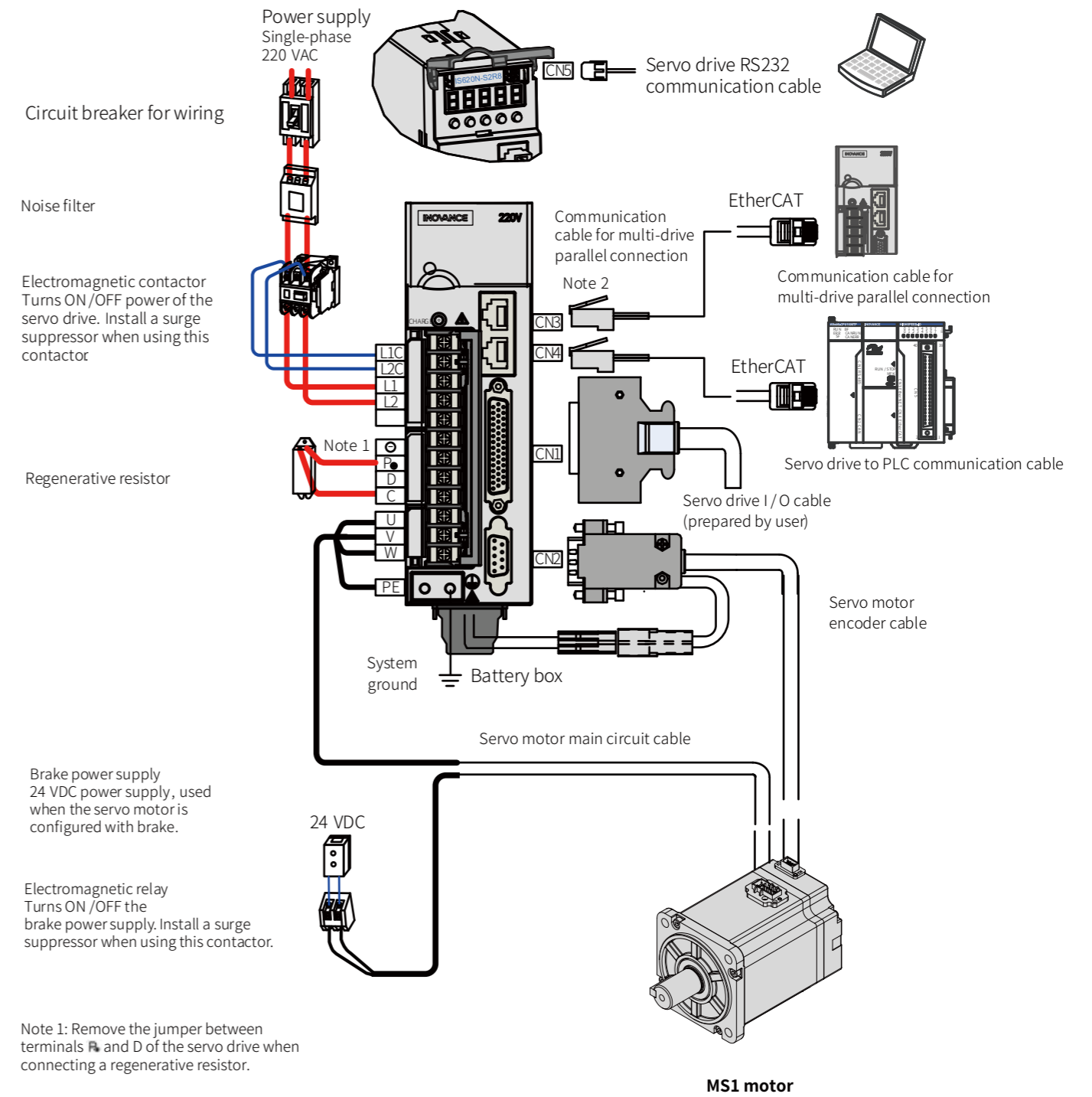

EtherCAT

# IS620N Servo Drive Configuration

Wiring example of three-phase 220V/380V system with EtherCAT network

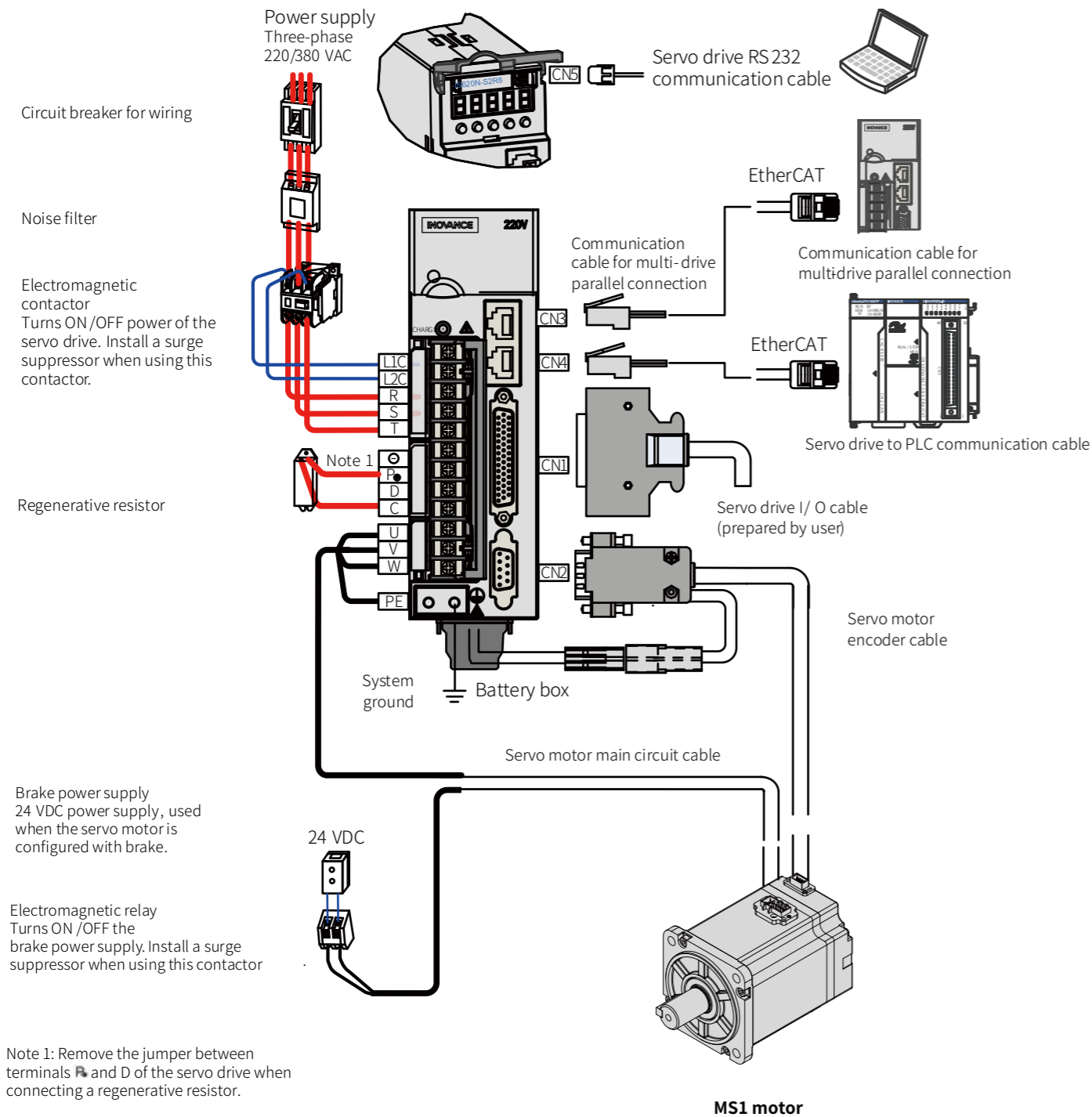

# IS620N Servo Drive Connection Diagram

Standard wiring for EtherCAT communication

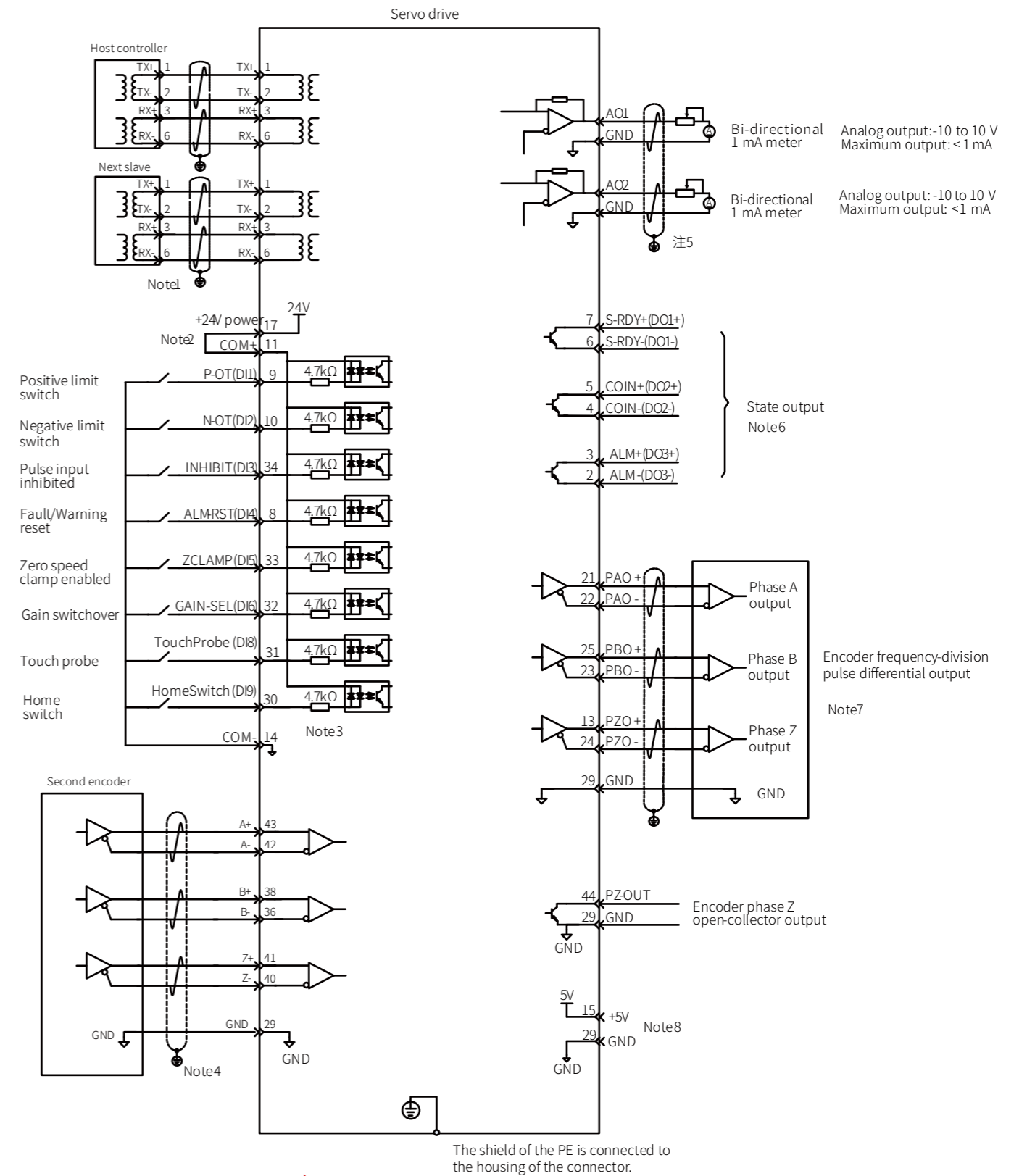

# IS620N EtherCAT Overview



EtherCAT is a high performance, flexible, cost-effective technology

## Open technology

EtherCAT is a high-performance, easy-to-use industrial Ethernet technology with a flexible topology. CoE (Can application protocol over EtherCAT) is the most commonly used EtherCAT communication protocol for acyclic data access. CoE also provides a mechanism to configure PDOs for cyclic data exchange.

The drive profile CiA402 (IEC61800-7-201) is mapped to EtherCAT. Our IS620N servo drive complies with CiA 402 profile.

- CIA 402 Profile type (CoE)
- Profile position mode (PP)
  - Profile velocity mode (PV)
  - Profile torque mode (PT)
  - Homing mode (HM)
  - Cyclic synchronous position mode (CSP)
  - Cyclic synchronous velocity mode (CSV)
  - Cyclic synchronous torque mode (CST)

## Example of EtherCAT network system with IS620N servo drive

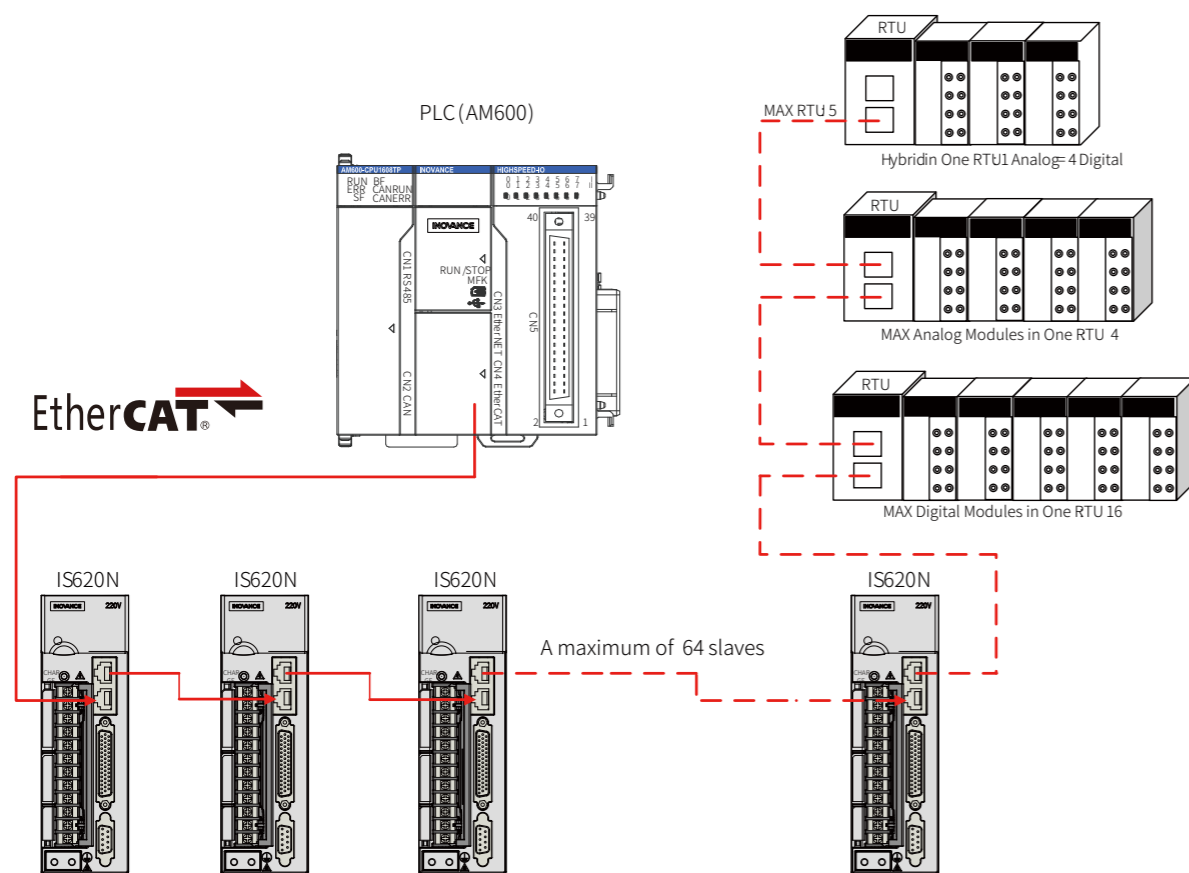

# IS620N EtherCAT Overview



## Network configuration using TwinCAT platform with IS620N

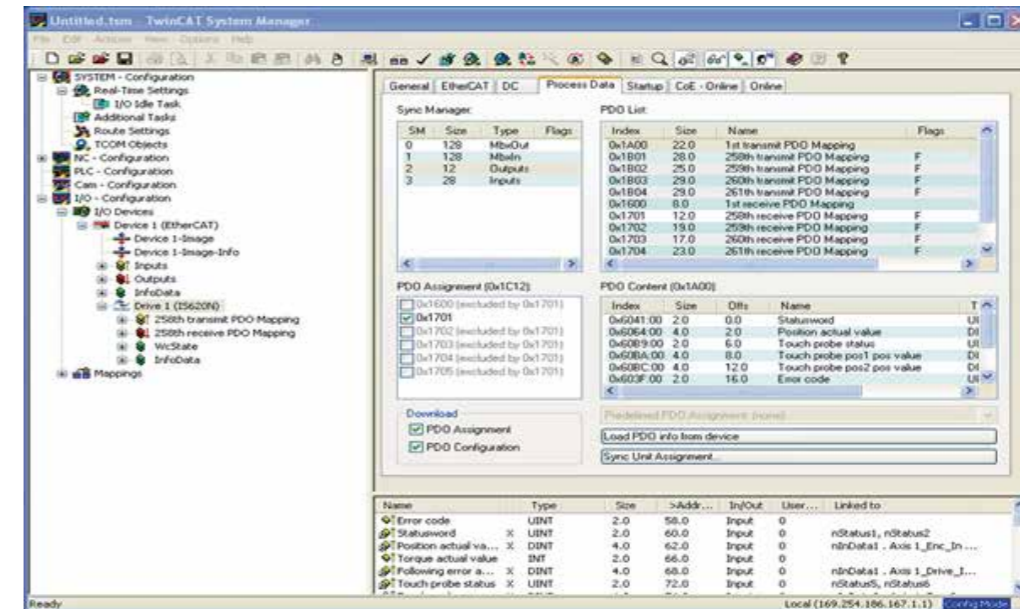

Configuration of the IS620N drive is automatically recognized by the controller using the XML library related to the drives.

## Network configuration using Trio Motion platform with IS620N

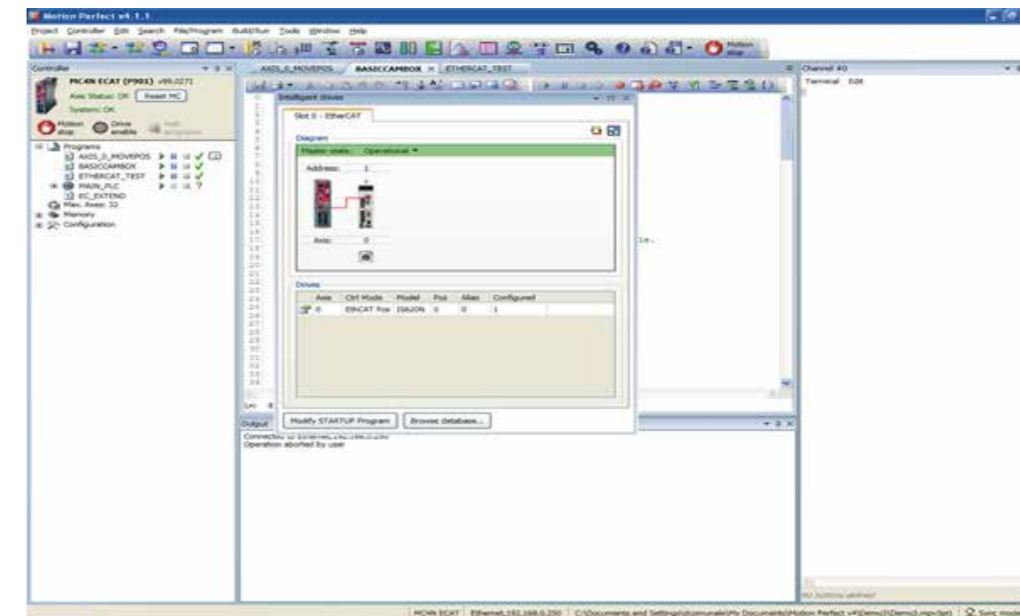

Configuration of the IS620N drive is automatically recognized by the controller using the XML library related to the drives.

# IS620N EtherCAT Overview



EtherCAT is a high performance, flexible, cost-effective technology

## Network configuration using AM600 platform with IS620N

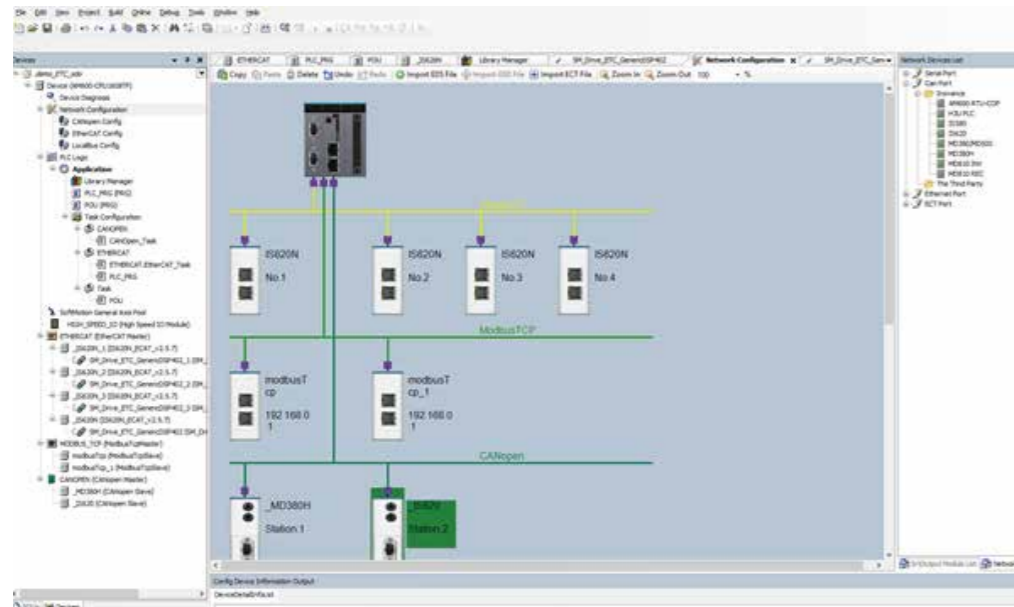

AM600 platform example of EtherCAT configuration + CANOpen module + Modbus TCP/IP for service and commissioning.

# IS620P-CO CANopen Overview



CANopen networks are used in many embedded machine control systems

The internationally standardized CiA 402 device profile for drives and motion controllers (IEC 61800-7-201/301) is the most widely implemented solution.

The CiA 402 profile specifies several operation modes in detail. They are selectable by means of a command, and confirmed at the application level.

CANopen supports Master/Slave mode, the IS620P only supports Slave mode. It supports only one master node in the network, the address of master/slave nodes is between 1 and 63, different for each node.

CiA 402	
■	0-Speed mode
■	1-Position mode
■	2-Torque mode
■	3-Speed mode<->Torque mode
■	4-Position mode<->Speed mode
■	5-Position mode<->Torque mode
■	6-Position<->speed<->Torque mode

Mode 3-6 can be changed on the fly

# IS620 Embedded Motion Overview

## Easy mode programming language for embedded motion

IS620P-CO-Embedded motion platform, gives the possibility to realize PLC programs directly on the drive, reducing cost and increasing performance. Dedicated motion functions reduces commissioning and tuning time. The embedded motion platform is supported by Modbus RTU to allow communication with an external device e.g. a PLC (CANopen communication is optional).

### Embedded Motion Block Diagram

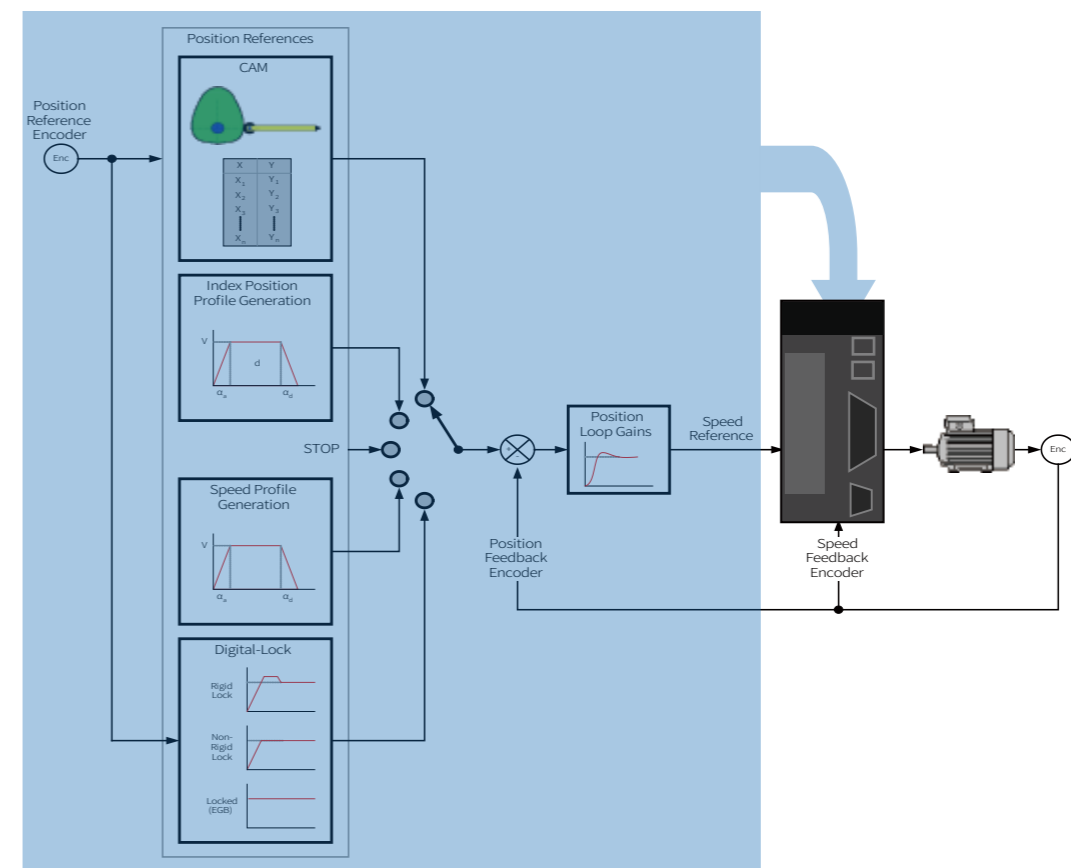

Available function	
■	Cam Function (1000 CP)
■	Digital lock
■	Profile Generator with position on fly change
■	Fast access to all drive data parameters
■	Easy mode programming

Easy mode programming	
■	Basic statement (For... Next, Do...while...)
■	Trigonometric function (Tan, Atan, Sin, Cos...)
■	Logical Operators (And, Or, Not...)
■	Motion functions
	FORWARD
	REVERSE
	MOVE
	MOVEABS
	CAMBOX_WRAP
	EPOS
	HPARAM



# IS620 Embedded Motion Examples

## Example 1 Electronic Cam

This code example shows how to use the cambox function. It combines a forward continuous movement with a sine profile generated by the cambox function.

```

REM Simple Cambox demo
PRINT VERSION$ ' print Motion basic revision
PRINT " Setting IS620P..." ' set rigidity level 21
PARAM("0901")=20 ' 2^23 encoder
encoder=8388608
UNIT(1) ' set unit = encoder count
ACCEL=20*encoder ' set the acceleration
DECEL=20*encoder ' set the deceleration
SPEED=5*encoder ' set the motor speed
CAMBOX_SPEED=2*encoder ' set the cambox master speed
PRINT "Motor Speed", 60*SPEED/encoder, "rpm" ' convert speed in rpm
PRINT "Set Cambox Table"
nstep=100
REM set first TABLE from 0 to nstep with sine profile
FOR I=0 TO nstep-1
SS=2000*SIN((6.28*I)/nstep)
TABLE(I, SS)
NEXT I
camcycles=5
PRINT "Set Cambox running for", camcycles, "cycles"
DATUM(0)
REM set option bit3=1 enable cam wrap interrupt, bit6=1 enable last cam cycle interrupt
camoption=8+64
CAMBOX_COUNT(1)=camcycles
ON CAMBOX_WRAP(1) GOSUB camboxwrap
ON CAMBOX_LAST(1) GOSUB camboxlast
CAMBOX(1, 0, nstep, 2000, 5*encoder, camoption)
WDOG(1)
FORWARD ' add forward movement to the cambox (composite movement)
WAIT(100)
FORWARD CAMBOX(1)
loopwait:
WAIT(400)
count=CAMBOX_COUNT(1)
IF count > 0 THEN loopwait
WAIT(1000)
WDOG(0)
END
camboxwrap:

```

## Example 2 MOVE Function

This code example shows how to use the MOVE function.

```

delay=500 ' set delay to 500ms
encoder=8388608 ' set for 2^23 encoder
step=10*encoder ' set n. of steps to move
FE_LIMIT(8*encoder) ' set the following error limit to 8 shaft turns
UNIT(1) ' set the unit in encoder count
ACCEL=10*encoder ' set acceleration
DECEL=10*encoder ' set deceleration
SPEED=2*encoder ' set speed 2 rps (120rpm)
DATUM(0) ' set the absolute position 0
WDOG(1) ' drive enable
PRINT "Actual position:", MPOS
MOVE(step) ' move from actual position of step count
WAIT_IDLE ' wait until the final position has not been reached
WAIT(delay) ' wait delay ms
PRINT "Actual position:", MPOS
MOVE(-step/2) ' move back from actual position of step/2 count
WAIT_IDLE ' wait until the final position has not been reached
WAIT(delay) ' wait delay ms
WDOG(0) ' drive disable
END ' end program

```

# PC Software InoServoShop

Easy to use engineering tool for commissioning and diagnostics



Easy auto-tuning using position JOG and self-adjustment

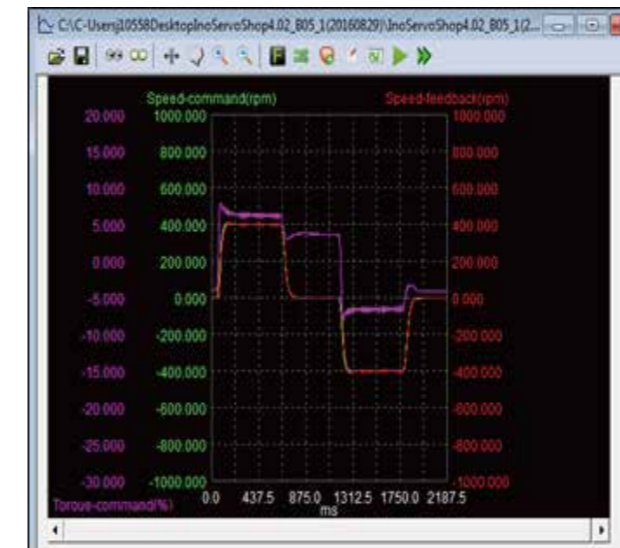

Oscilloscope function to monitor servo motor performance

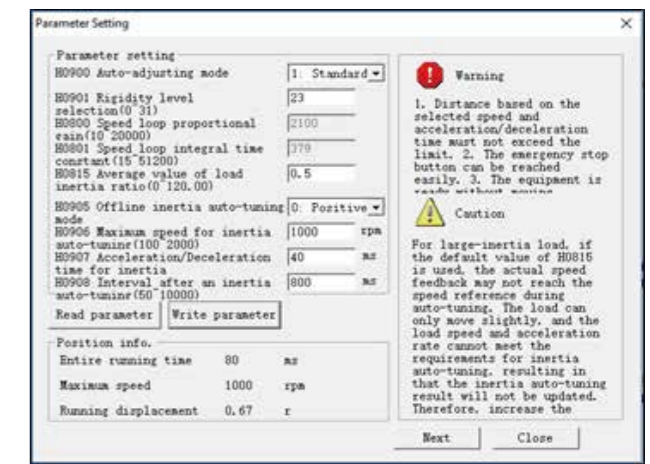

Inertia auto-tuning calculates estimated inertia of load

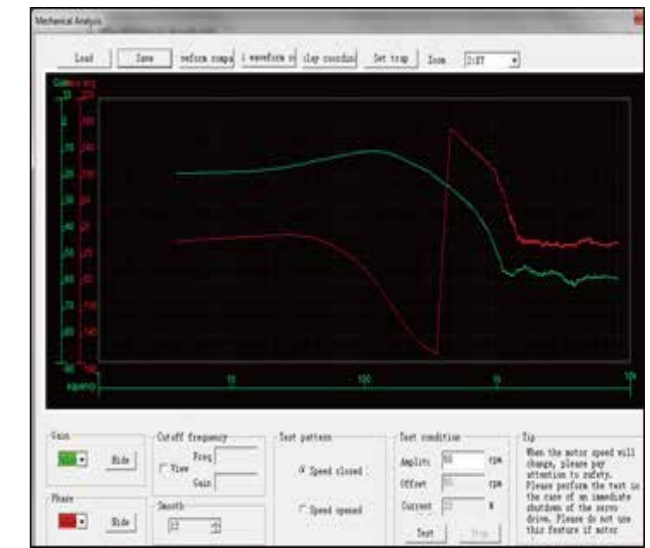

Mechanical analysis to diagnose natural frequency of system

- Function – Setting, Monitoring
  - Read/Write parameters
  - Real time monitoring parameters
  - DI/DO graphic configuration
  - Oscilloscope (Trace)
  - Software reset
  - JOG Run
  - Automatic U-V current phase calibration

- Function – Adjustment
  - Automatic gain tuning
  - Inertia auto-tuning
  - Mechanical analysis
- Advanced function
  - Electronic CAM

# Application Examples

## Double Position Loop Control

### Description

The encoder installed on the velocity measurement roller feeds back the actual speed and position signals of materials. The servo drive conducts closed-loop position control via the signals to ensure that the materials are delivered accurately and smoothly to the preset position. This function can effectively compensate slipping of materials and conveyors, and properly adjust gaps between the conveying processes. The dual-PG full closed-loop control function is powered by the algorithm integrated in the servo drive. The smoothness of speed and position control during the conveying process can be adjusted by the filter embedded in the drive. Besides, the runaway protection will function when the difference between positions of the internal and external loops is large. This ensures smooth and reliable conveying of materials.

### Applications

Steel plate cutting, Pipe bending, Wire stripping

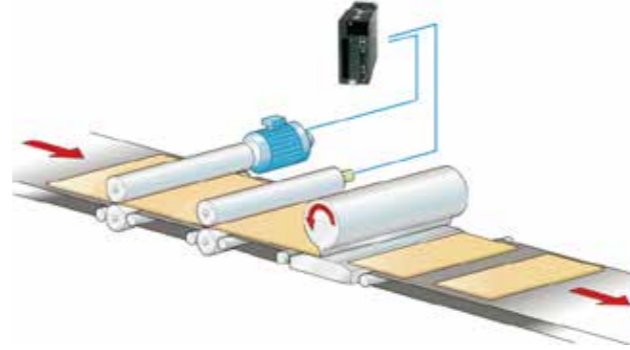

## Change On-fly Position Control

### Description

The servo drive runs position control and the fixed-length interruption function is enabled. After an external DI interruption function is input, the motor immediately runs to the preset length at the existing speed. The function has the highest priority, which ensures fast responding and shortest delay. When the function is effective, the servo motor does not respond to other position commands, thus preventing the influence of other commands sent to the servo motor.

### Applications

Material laying  
Bearing tube cutting

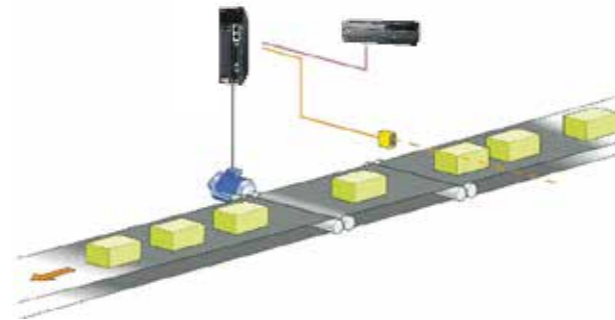

## CANlink Communication (optional)

### Description

CANlink is a communication protocol developed by INOVANCE based on the CAN bus. CANlink is an open protocol and allows connection of devices that support this protocol. Currently, CANlink 3.0 adopts the master-slave model, where there is but one master and at most 62 slaves. The highest communication rate is 1M. CANlink can realize networking of INOVANCE's HMIs, PLCs, servo drives and AC drives. It simplifies the networking process and improves reliability and resistance to interference. It can meet the demands of application scenarios that require large number of DIs and DOs. The standard CANopen protocol is also supported.

### Applications

Hoop bending, Film cutting, Automatic screwing, Stacking, Plastic injection molding, Other production processes

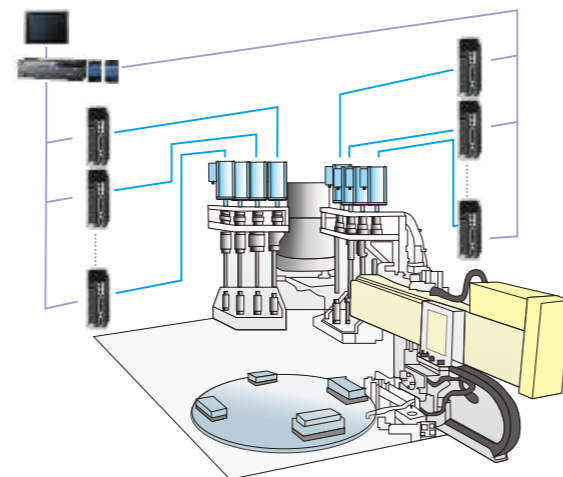

## Electronic Cam Control

### Description

The encoder installed on the velocity measurement roller feeds back actual speed and position signals of materials. The servo drive uses the signals as signals of the master axis and programs a position curve for the slave axis (servo motor). The servo motor runs this curve. This function substitutes the mechanical cam in an electronic way to reduce mechanical input and easily realizes change of cam curves without maintaining or changing cams.

Rotary cutting, flying cutting and flying saw functions can be realized.

### Applications

Printing machines  
Flying cutting

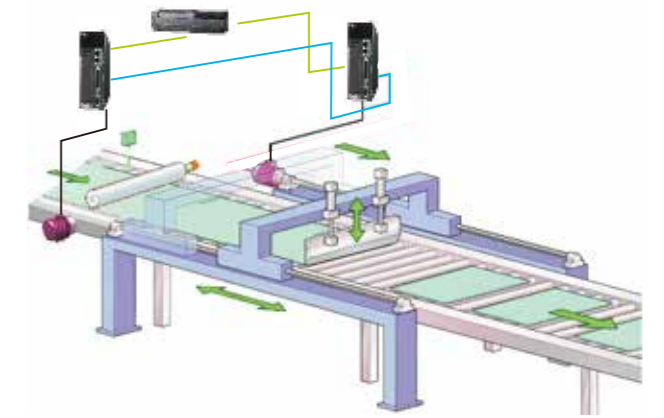

## Gantry Synchronization

### Description

The host sends pulse references to two servo drives simultaneously. Encoders on the two servo motors feed back position pulses. The servo drives interact and cross-couple these pulse signals to adjust the speeds of the motors in real time, so that the two axes are synchronized. Dual-axis drive control can be used in applications where there are large gantry structures to reduce mechanical coupling.

The virtual synchronization controllers inside the servo drives can continuously track synchronization and sound an alarm when the position deviation exceeds the preset limit to stop the system.

### Applications

Large facing machine  
Welding and cutting

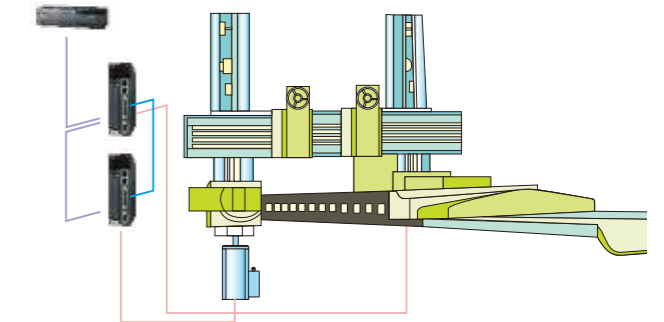

## Multi-Position Control

### Description

Control of up to 16 positions can be realized through combinations of input terminals, by selecting different in-built position references (relative or absolute positions) previously preset by PLC via communications or by manual input.

Up to 16 positions are supported. To use this function servo motor installed with multi-turn absolute encoder is required, and the home seek operation needs to be performed. During the operation of multi-position control, a position-reach signal will be given when each phase is completed.

### Applications

Longitudinal line cutting  
Multi-station switching  
Servo tool holder

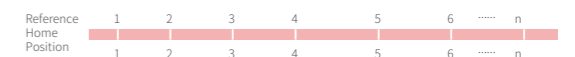
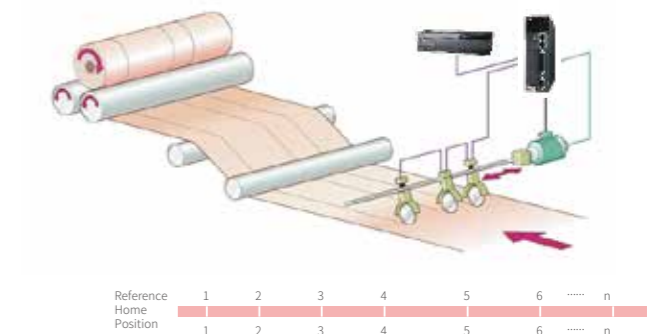

# MS1 Servo Motor Technical Data

Reliable operation, wide selection

## Model designation

# MS1 H1 - 75B 30C B - A3 3 1 Z - INT

① ② ③ ④ ⑤ ⑥ ⑦ ⑧ ⑨ ⑩

① Series: MS1 series servo motor	④ Rated speed A: x 1 B: x 10 C: x 100 D: x 1000 E: x 10000 E.g. 30C : 3000 RPM	⑦ Motor shaft 1: Plain 2: Keyed 3: Keyed + tapped hole 5: Tapped hole
② Inertia H1: Low inertia, 40/60/80 mm flange H2: Low inertia, 100/130 mm flange H3: Medium inertia 130/180 mm flange H4: Medium inertia 60/80 mm flange	⑤ Voltage class B: 220V D: 380V	⑧ Brake, Oil sealing 0: None 1: Oil sealing 2: Brake 4: Brake + Oil sealing
③ Rated power A: x 1 B: x 10 C: x 100 D: x 1000 E: x 10000 E.g. 75B : 750W; 15C : 1500W	⑥ Encoder type U2: 20-bit serial incremental A3: 23-bit multi-turn absolute	⑨ Motor configuration Y: 8 pole Z: 10 pole
		⑩ INT: international version

Servo motor model	Rated output [kW]	Rated torque [Nm]	Peak torque [Nm]	Rated current [Arms]	Peak current [Arms]	Rated speed [RPM]	Peak speed [RPM]	Torque constant [Nm/Arms]	Rotar inertia [10 <sup>-4</sup> x kgm <sup>2</sup> ]	Voltage [V]	
<b>MS1H1 (N<sub>rated</sub> = 3,000 RPM, N<sub>max</sub> = 6,000 RPM)</b>											
MS1H1-05B30CB-□□□□Z-INT	0.05	0.16	0.56	1.3	4.7	3,000	6,000	0.15	0.026 (0.028)	220	
MS1H1-10B30CB-□□□□Z-INT	0.1	0.32	1.12	1.3	4.7			0.26	0.041 (0.043)		
MS1H1-20B30CB-□□□□Z-INT	0.2	0.64	2.24	1.5	5.8			0.46	0.207 (0.220)		
MS1H1-40B30CB-□□□□Z-INT	0.4	1.27	4.46	2.8	10.1			0.53	0.376 (0.390)		
MS1H1-55B30CB-□□□□Z-INT	0.55	1.75	6.13	3.8	15.0			0.49	1.06		
MS1H1-75B30CB-□□□□Z-INT	0.75	2.39	8.36	4.8	16.9			0.58	1.38 (1.43)		
MS1H1-10C30CB-□□□□Z-INT	1.0	3.18	11.1	7.6	28			0.46	1.75		
<b>MS1H2 (N<sub>rated</sub> = 3,000 RPM, N<sub>max</sub> = 5,000/6,000 RPM)</b>											
MS1H2-10C30CB-□□□□Y-INT	1.0	3.18	9.54	7.5	23	3,000	6,000	0.43	1.87 (3.12)	220	
MS1H2-15C30CB-□□□□Y-INT	1.5	4.9	14.7	10.8	32		5,000	0.45	2.46 (3.71)		
MS1H2-10C30CD-□□□□Y-INT	1.0	3.18	9.54	3.65	11		6,000	0.87	1.87 (3.12)	380	
MS1H2-15C30CD-□□□□Y-INT	1.5	4.9	14.7	4.5	14		5,000	1.09	2.46 (3.71)		
MS1H2-20C30CD-□□□□Y(-S4)-INT	2.0	6.36	19.1	5.89	20			1.08	3.06 (4.31)		
MS1H2-25C30CD-□□□□Y(-S4)-INT	2.5	7.96	23.9	7.56	25			1.05	3.65 (4.9)		
MS1H2-30C30CD-□□□□Y(-S4)-INT	3.0	9.8	29.4	10	30			0.98	7.72 (7.72)		
MS1H2-40C30CD-□□□□Y(-S4)-INT	4.0	12.6	37.8	13.6	40.8		0.93	12.1 (14.6)			
MS1H2-50C30CD-□□□□Y(-S4)-INT	5.0	15.8	47.6	16	48		1.07	15.4 (17.9)			
<b>MS1H3 (N<sub>rated</sub> = 1,500 RPM, N<sub>max</sub> = 3,000 RPM)</b>											
MS1H3-85B15CB-□□□□Z-INT	0.85	5.39	13.5	6.6	16.5		1,500	3,000	0.9	13.3 (14)	220
MS1H3-13C15CB-□□□□Z-INT	1.3	8.34	20.85	10	25				0.9	17.8 (18.5)	
MS1H3-85B15CD-□□□□Z-INT	0.85	5.39	13.5	3.3	8.25				1.75	13.3 (14)	380
MS1H3-13C15CD-□□□□Z-INT	1.3	8.34	20.85	5	12.5				1.78	17.8 (18.5)	
MS1H3-18C15CD-□□□□Z-INT	1.8	11.5	28.75	6.6	16.5	1.8			25 (25.7)		
MS1H3-29C15CD-□□□□Z-INT	2.9	18.6	37.2	11.9	28	1.7			55 (57.2)		
MS1H3-44C15CD-□□□□Z-INT	4.4	28.4	71.1	16.5	40.5	1.93			88.9 (90.8)		
MS1H3-55C15CD-□□□□Z-INT	5.5	35	87.6	20.85	52	1.8			107 (109.5)		
MS1H3-75C15CD-□□□□Z-INT	7.5	48	119	25.7	65	1.92			141 (143.1)		
<b>MS1H4 (N<sub>rated</sub> = 3,000 RPM, N<sub>max</sub> = 6,000 RPM)</b>											
MS1H4-40B30CB-□□□□Z-INT	0.4	1.27	4.46	2.8	10.1	3,000	6,000	0.53	0.657 (0.667)	220	
MS1H4-75B30CB-□□□□Z-INT	0.75	2.39	8.36	4.8	16.9			0.58	2 (2.012)		

Notes: Brake version can only work in S4 duty, for example ISMH2-20C30CD-A334Y-S4-INT.

# Servo Motor and Servo Drive Combination

	1-phase 220V		1/3-phase 220V	3-phase 220V				
Servo Drive								
	SIZE A		SIZE A	SIZE C		SIZE E		
	IS620□S1R6I	IS620□S2R8I	IS620□S5R5I	IS620□S7R6I	IS620□S012I	IS620□S018I		
Servo Motor								
	50 W, 100 W, 200 W	400 W	550 W, 750 W	850 W, 1.0 kW	1.3 kW, 1.5 kW	2.0 kW	2.5 kW, 3.0 kW	
	MS1H1-05B30CB MS1H1-10B30CB MS1H1-20B30CB	MS1H1-40B30CB MS1H4-40B30CB	MS1H1-55B30CB (no brake) MS1H1-75B30CB MS1H4-75B30CB	MS1H1-10C30CB (no brake) MS1H2-10C30CB MS1H3-85B15CB	MS1H3-13C15CB MS1H2-15C30CB	MS1H2-20C30CB	MS1H2-20C30CB MS1H2-25C30CB	
Servo Drive	3-phase 380V							
	SIZE C			SIZE E				
	IS620□T3R5I	IS620□T5R4I	IS620□T8R4I	IS620□T012I	IS620□T017I	IS620□T021I	IS620□T026I	
Servo Motor								
	850 W	1.0 kW, 1.3 kW, 1.5 kW	1.8 kW, 2.0 kW, 2.5 kW	2.9 kW, 3.0 kW	4.0 kW, 4.4 kW, 5.0 kW	5.5 kW	7.5 kW	
	MS1H3-85B15CD	MS1H3-13C15CD MS1H2-10C30CD MS1H2-15C30CD	MS1H3-18C15CD MS1H2-20C30CD MS1H2-25C30CD	MS1H3-29C15CD MS1H2-30C30CD	MS1H3-44C15CD MS1H2-40C30CD MS1H2-50C30CD	MS1H3-55C15CD	MS1H3-75C15CD	

# Servo Motor Dimensions and Drawings

MS1H1 mounting dimensions ( $N_{rated} = 3,000 \text{ RPM}$ ,  $N_{max} = 6,000 \text{ RPM}$ )

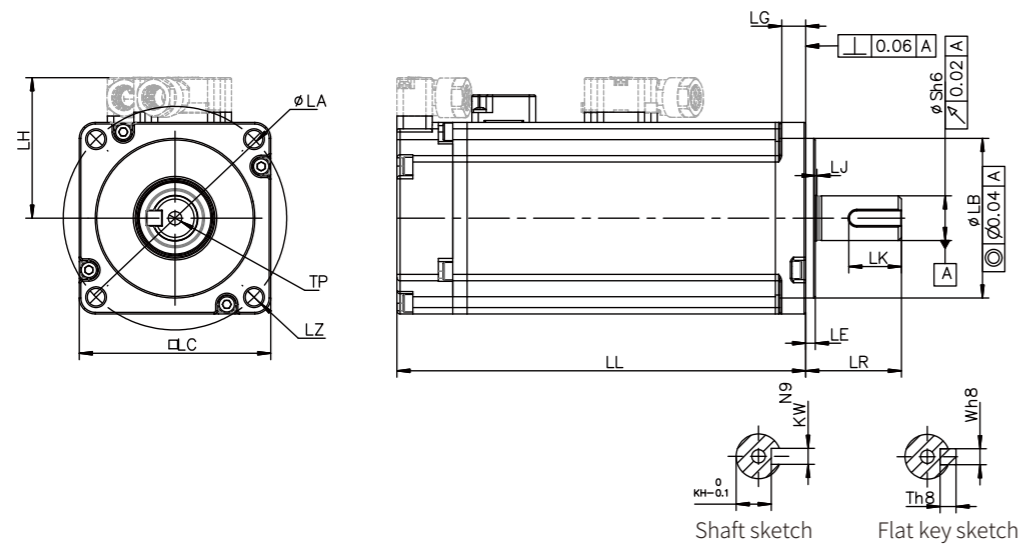

Model	LC (mm)	LL (mm)	LR (mm)	LA (mm)	LZ (mm)	LH (mm)	LG (mm)	LE (mm)	LJ (mm)
MS1H1-05B30CB -□□□□Z-INT	40	65 (96)	25±0.5	46	2-Φ4.5	34	5	2.5±0.5	0.5±0.35
MS1H1-10B30CB -□□□□Z-INT	40	77.5 (109)	25±0.5	46	2-Φ4.5	34	5	2.5±0.5	0.5±0.35
MS1H1-20B30CB -□□□□Z-INT	60	72.5 (100)	30±0.5	70	4-Φ5.5	44	7.5	3±0.5	0.5±0.35
MS1H1-40B30CB -□□□□Z-INT	60	91 (119)	30±0.5	70	4-Φ5.5	44	7.5	3±0.5	0.5±0.35
MS1H1-55B30CB -□□□□Z-INT	80	96.2	35±0.5	90	4-Φ7	54	7.7	3±0.5	0.5±0.35
MS1H1-75B30CB -□□□□Z-INT	80	107 (140)	35±0.5	90	4-Φ7	54	7.7	3±0.5	0.5±0.35
MS1H1-10C30CB -□□□□Z-INT	80	118.2	35±0.5	90	4-Φ7	54	7.7	3±0.5	0.5±0.35

Model	LB (mm)	S (mm)	TP (mm)	LK (mm)	KH (mm)	KW (mm)	W (mm)	T (mm)	Weight (kg)
MS1H1-05B30CB -□□□□Z-INT	30	8	M3×6	15.5	6.2	3	3	3	0.39 (0.50)
MS1H1-10B30CB -□□□□Z-INT	30	8	M3×6	15.5	6.2	3	3	3	0.45 (0.64)
MS1H1-20B30CB -□□□□Z-INT	50	14	M5×8	16.5	11	5	5	5	0.78 (1.16)
MS1H1-40B30CB -□□□□Z-INT	50	14	M5×8	16.5	11	5	5	5	1.11 (1.48)
MS1H1-55B30CB -□□□□Z-INT	70	19	M6×20	25	15.5	6	6	6	1.85
MS1H1-75B30CB -□□□□Z-INT	70	19	M6×20	25	15.5	6	6	6	2.18 (2.82)
MS1H1-10C30CB -□□□□Z-INT	70	19	M6×20	25	15.5	6	6	6	2.55

# Servo Motor Dimensions and Drawings

MS1H2 mounting dimensions ( $N_{rated} = 3,000 \text{ RPM}$ ,  $N_{max} = 5,000/6,000 \text{ RPM}$ )

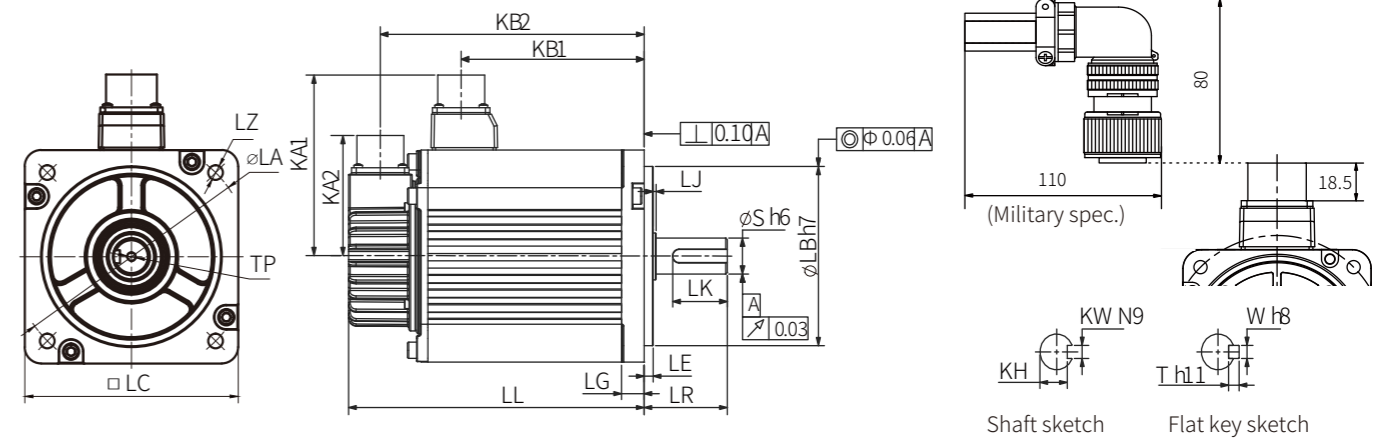

Model	LC (mm)	LL (mm)	LR (mm)	LA (mm)	LZ (mm)	KA1 (mm)	KB1 (mm)	KA2 (mm)	KB2 (mm)	LG (mm)	LE (mm)	LJ (mm)	LB (mm)
MS1H2-10C30CB(D) -□□□□Y-INT	100	164 (213.5)	45±1	115	4-Φ7	88	94.5 (101)	74	143.5 (192.5)	10	5±0.3	2.5±0.75	95
MS1H2-15C30CB(D) -□□□□Y-INT	100	189 (239)	45±1	115	4-Φ7	88	119.5 (128)	74	168.5 (219.5)	10	5±0.3	2.5±0.75	95
MS1H2-20C30CD -□□□□Y(-S4)-INT	100	214 (265)	45±1	115	4-Φ7	88	144.5 (153)	74	193.5 (244)	10	5±0.3	2.5±0.75	95
MS1H2-25C30CD -□□□□Y(-S4)-INT	100	240.5 (290)	45±1	115	4-Φ7	88	169.5 (178)	74	218.5 (269)	10	5±0.3	2.5±0.75	95
MS1H2-30C30CD -□□□□Y(-S4)-INT	130	209.5 (265.5)	63±1	145	4-Φ9	103	136 (139)	74	188.5 (244.5)	14	6±0.3	0.5±0.75	110
MS1H2-40C30CD -□□□□Y(-S4)-INT	130	252 (308)	63±1	145	4-Φ9	103	178.5 (181.5)	74	231 (287)	14	6±0.3	0.5±0.75	110
MS1H2-50C30CD -□□□□Y(-S4)-INT	130	294.5 (350.5)	63±1	145	4-Φ9	103	221 (224)	74	273.5 (329.5)	14	6±0.3	0.5±0.75	110

Model	S (mm)	TP (mm)	LK (mm)	KH (mm)	KW (mm)	W (mm)	T (mm)	Weight (kg)	Conn-ector	Power Side (incl. Power Brake Side)	Encoder Side
MS1H2-10C30CB(D) -□□□□Y-INT	24	M8×16	36	20 <sup>0</sup> <sub>-0.2</sub>	8	8	7	5.11 (6.41)	Aviation plug	MI-DTL-5015 3102E20-18P	MI-DTL-5015 3102E20-29P
MS1H2-15C30CB(D) -□□□□Y-INT	24	M8×16	36	20 <sup>0</sup> <sub>-0.2</sub>	8	8	7	6.22 (7.52)			
MS1H2-20C30CD -□□□□Y(-S4)-INT	24	M8×16	36	20 <sup>0</sup> <sub>-0.2</sub>	8	8	7	7.39 (8.7)			
MS1H2-25C30CD -□□□□Y(-S4)-INT	24	M8×16	36	20 <sup>0</sup> <sub>-0.2</sub>	8	8	7	8.55 (9.8)			
MS1H2-30C30CD -□□□□Y(-S4)-INT	28	M8×20	54	24 <sup>0</sup> <sub>-0.2</sub>	8	8	7	10.73 (13.2)	Aviation plug	MI-DTL-5015 3102E20-18P	MI-DTL-5015 3102E20-29P
MS1H2-40C30CD -□□□□Y(-S4)-INT	28	M8×20	54	24 <sup>0</sup> <sub>-0.2</sub>	8	8	7	15.43 (17.9)			
MS1H2-50C30CD -□□□□Y(-S4)-INT	28	M8×20	54	24 <sup>0</sup> <sub>-0.2</sub>	8	8	7	16.2 (18.7)			

# Servo Motor Dimensions and Drawings

MS1H3 mounting dimensions ( $N_{rated} = 1,500 \text{ RPM}$ ,  $N_{max} = 3,000 \text{ RPM}$ )

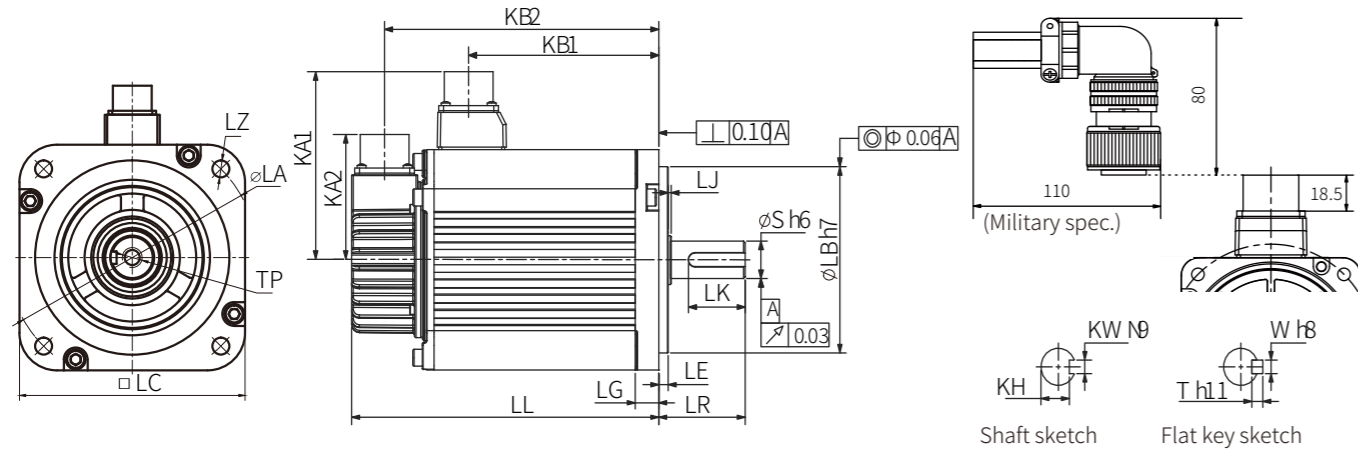

Model	LC (mm)	LL (mm)	LR (mm)	LA (mm)	LZ (mm)	KA1 (mm)	KB1 (mm)	KA2 (mm)	KB2 (mm)	LG (mm)	LE (mm)	LJ (mm)	LB (mm)
MS1H3-85B15CB(D) -□□□□Z-INT	130	146 (182)	55±1	145	4-Φ9	103	72.5	74	125 (161)	14	4	0.5±0.75	110
MS1H3-13C15CB(D) -□□□□Z-INT	130	163 (199)	55±1	145	4-Φ9	103	89.5	74	142 (178)	14	4	0.5±0.75	110
MS1H3-18C15CD -□□□□Z-INT	130	181 (217)	55±1	145	4-Φ9	103	107.5	74	160 (196)	14	4	0.5±0.75	110
MS1H3-29C15CD -□□□□Z-INT	180	197 (273)	79±1	200	4-Φ13.5	138	136 (134)	74	177 (253)	18	3.2±0.3	0.3±0.75	114.3
MS1H3-44C15CD -□□□□Z-INT	180	230 (307)	79±1	200	4-Φ13.5	138	169 (167)	74	210 (286)	18	3.2±0.3	0.3±0.75	114.3
MS1H3-55C15CD -□□□□Z-INT	180	274 (350)	113±1	200	4-Φ13.5	138	213 (211)	74	254 (330)	18	3.2±0.3	0.3±0.75	114.3
MS1H3-75C15CD -□□□□Z-INT	180	330 (407)	113±1	200	4-Φ13.5	138	269 (267)	74	310 (386)	18	3.2±0.3	0.3±0.75	114.3

Model	S (mm)	TP (mm)	LK (mm)	KH (mm)	KW (mm)	W (mm)	T (mm)	Weight (kg)	Conn-ector	Power Side (incl. Power Brake Side)	Encoder Side
MS1H3-85B15CB(D) -□□□□Z-INT	22	M6×20	36	18 <sup>0</sup> <sub>-0.2</sub>	8	8	7	7 (8)	Aviation plug	MI-DTL-5015 3102E20-18P	MI-DTL-5015 3102E20-29P
MS1H3-13C15CB(D) -□□□□Z-INT	22	M6×20	36	18 <sup>0</sup> <sub>-0.2</sub>	8	8	7	8 (9.5)			
MS1H3-18C15CD -□□□□Z-INT	22	M6×20	36	18 <sup>0</sup> <sub>-0.2</sub>	8	8	7	9.5 (11)			
MS1H3-29C15CD -□□□□Z-INT	35	M12×25	65	30 <sup>0</sup> <sub>-0.2</sub>	10	10	8	15 (25)	Aviation plug	MI-DTL-5015 3102E20-22P	MI-DTL-5015 3102E20-29P
MS1H3-44C15CD -□□□□Z-INT	35	M12×25	65	30 <sup>0</sup> <sub>-0.2</sub>	10	10	8	19.5 (30)			
MS1H3-55C15CD -□□□□Z-INT	42	M16×32	96	37 <sup>0</sup> <sub>-0.2</sub>	12	12	8	28 (38)			
MS1H3-75C15CD -□□□□Z-INT	42	M16×32	96	37 <sup>0</sup> <sub>-0.2</sub>	12	12	8	32 (42)			

# Servo Motor Dimensions and Drawings

MS1H4 mounting dimensions ( $N_{rated} = 3,000 \text{ RPM}$ ,  $N_{max} = 6,000 \text{ RPM}$ )

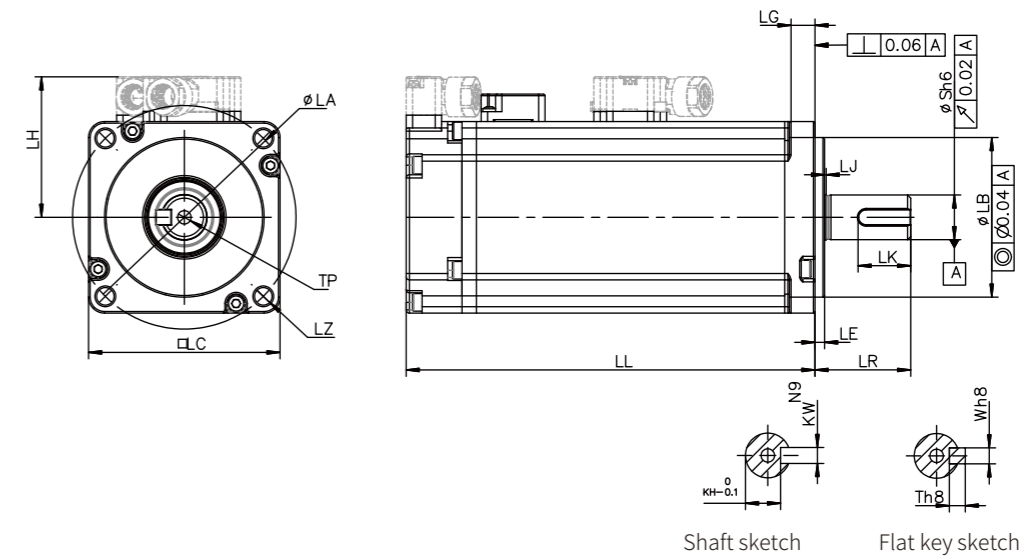

Model	LC (mm)	LL (mm)	LR (mm)	LA (mm)	LZ (mm)	LH (mm)	LG (mm)	LE (mm)	LJ (mm)
MS1H4-40B30CB -□□□□Z-INT	60	105 (128)	30±0.5	70	4-Φ5.5	44	7.5	3±0.3	0.5±0.35
MS1H4-75B30CB -□□□□Z-INT	80	117.5 (147.5)	35±0.5	90	4-Φ7	54	7.7	3±0.3	0.5±0.35

Model	LB (mm)	S (mm)	TP (mm)	LK (mm)	KH (mm)	KW (mm)	W (mm)	T (mm)	Weight (kg)
MS1H4-40B30CB -□□□□Z-INT	50	14	M5×8	16.5	11.0	5	5	5	1.27 (1.62)
MS1H4-75B30CB -□□□□Z-INT	70	19	M6×20	25	15.5	6	6	6	2.40 (3.04)

# Servo Motor Torque Vs Speed Graph

A (Continuous operation area) & B (Short term operation area)

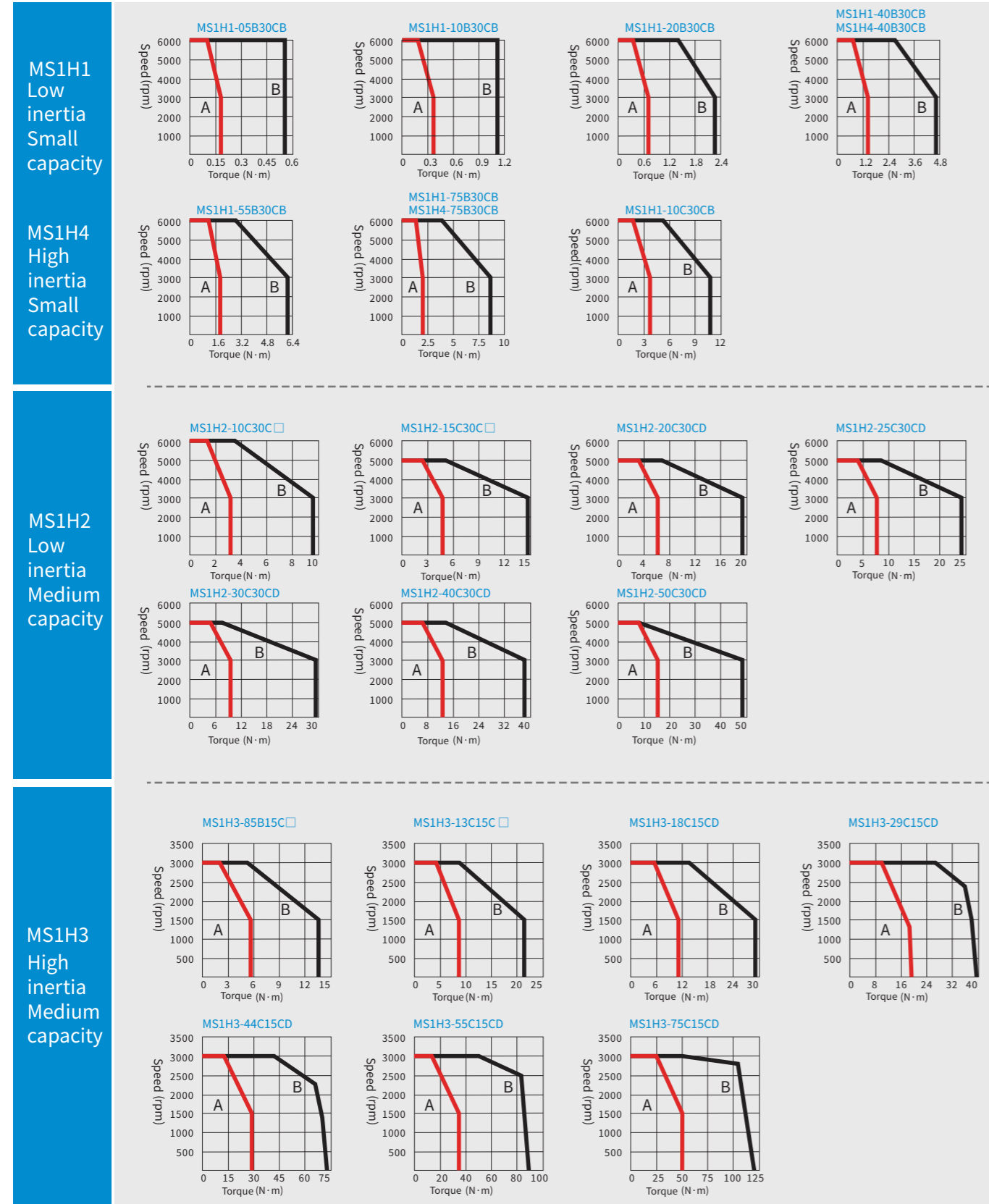

# Servo Motor Overload Characteristic Graph

MS1H1/MS1H2/MS1H3/MS1H4

Load in%	Deceleration time(s)
120	230
130	80
140	40
150	30
160	20
170	17
180	15
190	12
200	10
210	8.5
220	7
230	6
240	5.5
250	5
300	3
350	2

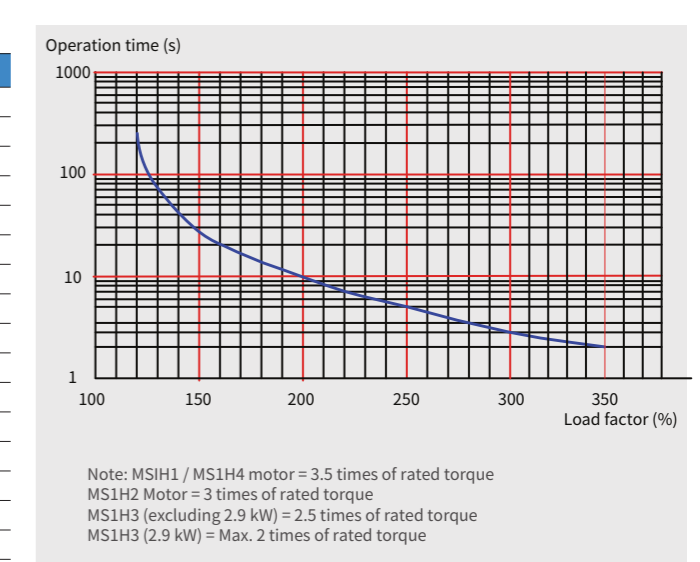

# Allowable Radial Load, Axial Load

Servo motor model	Allowable radial load (N)	Allowable axial load (N)
MS1H1-05B30CB-U3□□Z/A3□□Z-INT	78	54
MS1H1-10B30CB-U3□□Z/A3□□Z-INT	78	54
MS1H1-20B30CB-U3□□Z/A3□□Z-INT	245	74
MS1H1-40B30CB-U3□□Z/A3□□Z-INT	245	74
MS1H1-55B30CB-U3□1Z/A3□1Z-INT	392	147
MS1H1-75B30CB-U3□□Z/A3□□Z-INT	392	147
MS1H1-10C30CB-U3□1Z/A3□1Z-INT	392	147
MS1H2-10C30C□-U2□□Z/A3□□Z-INT	686	196
MS1H2-15C30C□-U2□□Z/A3□□Z-INT	686	196
MS1H2-20C30CD-U2□□Y/A3□□Y(-S4)-INT	686	196
MS1H2-25C30CD-U2□□Y/A3□□Y(-S4)-INT	686	196
MS1H2-30C30CD-U2□□Y/A3□□Y(-S4)-INT	980	392
MS1H2-40C30CD-U2□□Y/A3□□Y(-S4)-INT	1176	392
MS1H2-50C30CD-U2□□Y/A3□□Y(-S4)-INT	1176	392
MS1H3-85B15C□-U3□□Z/A3□□Z-INT	686	196
MS1H3-13C15C□-U3□□Z/A3□□Z-INT	686	196
MS1H3-18C15CD-U3□□Z/A3□□Z-INT	686	196
MS1H3-29C15CD-U2□□Z/A3□□Z-INT	1470	490
MS1H3-44C15CD-U2□□Z/A3□□Z-INT	1470	490
MS1H3-55C15CD-U2□□Z/A3□□Z-INT	1764	588
MS1H3-75C15CD-U2□□Z/A3□□Z-INT	1764	588
MS1H4-40B30CB-U3□□Z/A3□□Z-INT	245	74
MS1H4-75B30CB-U3□□Z/A3□□Z-INT	392	147

# Brake Specifications

Model	Holding torque (Nm)	Input voltage (V) (±10%)	Resistance (Ω)	Input current (A) (±7%)	Opening time (ms)	Closing time (ms)	Power (W)
MS1H1-05/10B	0.3	24	96	0.23~0.27	10	30	6.1
MS1H1-20B/40B	1.5		82.3	0.25~0.34	20	50	7.6
MS1H1-75B	2.5		50.1	0.40~0.57	25	60	8
MS1H2-10C/15C/20C/25C	8		25	0.81~1.14	30	90	20
MS1H2-30C/40C/50C	16		21.3	0.95~1.33	60	120	19.4
MS1H3-85B/13C/18C	12		21.3	0.95~1.33	60	120	19.4
MS1H3-29C/44C/55C/75C	48		13.7	1.47~2.07	100	230	40
MS1H4-40B	1.5		82.3	0.25~0.34	20	50	7.6
MS1H4-75B	2.5		50.1	0.40~0.57	25	60	8

# Servo Motor Encoder and Power Wiring Details

## Motor connections description

□40, □60, □80 Frame size motor end connector



Motos end power 6-PIN connector

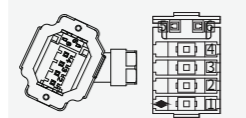

Pin No.	Signal
1	PE
2	W
3	V
4	U
5	Brake (No polarity)
6	

Drive end encoder 9-PIN connector

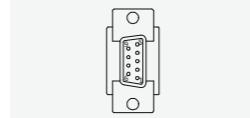

Pin No.	Signal
1	PS+
2	PS-
7	+5V
8	0V

Motor end encoder 7-PIN connector

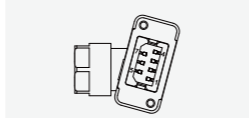

Pin No.	Signal
1	PS+
2	PS-
3	DC+
4	DC-
5	+5V
6	0V
7	PE

□100, □130 Frame size motor end connector



Motor end power 20-18 military connector

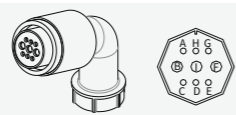

MIL-DTL-5015 Series 3108E20-18S			
Y-Series terminal		Z-Series terminal	
Pin No.	Signal	Pin No.	Signal
B	U	B	U
I	V	I	V
F	W	F	W
G	PE	G	PE
C	Brake (No polarity)		
E			

Motor end encoder 20-29 military connector

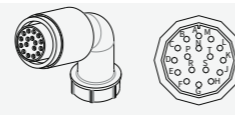

MIL-DTL-5015 Series 3108E20-29S		
Pin No.	Signal	
	20-bit Incremental	23-bit Absolute
A	PS+	PS+
B	PS-	PS-
C	-	-
D	-	-
E	-	Battery+
F	-	Battery-
G	+5V	+5V
H	GND	GND
J	Shield	Shield

□180 Frame size motor end connector



Motor end power 20-22 military connector



MIL-DTL-5015 Series 3108E20-22S			
Y-Series terminal		Z-Series terminal	
Pin No.	Signal	Pin No.	Signal
A	U	A	U
C	V	C	V
E	W	E	W
F	PE	F	PE
		B	Brake (No polarity)
		D	

Motor end encoder 20-29 military connector

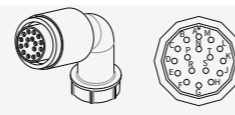

MIL-DTL-5015 Series 3108E20-29S		
Pin No.	Signal	
	20-bit Incremental	23-bit Absolute
A	PS+	PS+
B	PS-	PS-
C	-	-
D	-	-
E	-	Battery+
F	-	Battery-
G	+5V	+5V
H	GND	GND
J	Shield	Shield

# Motor Power Cable Item Codes

Model	Servo motor power cable- Cable direction toward front side					
	Without brake			With brake		
	L = 3.0 m	L = 5.0 m	L = 10.0 m	L = 3.0 m	L = 5.0 m	L = 10.0 m
MS1H1	S6-L-M007-3.0	S6-L-M007-5.0	S6-L-M007-10.0	S6-L-B007-3.0	S6-L-B007-5.0	S6-L-B007-10.0
MS1H4	S6-L-M007-3.0	S6-L-M007-5.0	S6-L-M007-10.0	S6-L-B007-3.0	S6-L-B007-5.0	S6-L-B007-10.0

Model	Servo motor power cable- Cable direction towards back side					
	Without brake			With brake		
	L = 3.0 m	L = 5.0 m	L = 10.0 m	L = 3.0 m	L = 5.0 m	L = 10.0 m
MS1H1	S6-L-M008-3.0	S6-L-M008-5.0	S6-L-M008-10.0	S6-L-B008-3.0	S6-L-B008-5.0	S6-L-B008-10.0
MS1H4	S6-L-M008-3.0	S6-L-M008-5.0	S6-L-M008-10.0	S6-L-B008-3.0	S6-L-B008-5.0	S6-L-B008-10.0

Model	Servo motor power cable					
	Without brake			With brake		
	L = 3.0 m	L = 5.0 m	L = 10.0 m	L = 3.0 m	L = 5.0 m	L = 10.0 m
MS1H2	S6-L-M11-3.0	S6-L-M11-5.0	S6-L-M11-10.0	S6-L-B11-3.0	S6-L-B11-5.0	S6-L-B11-10.0
MS1H3 (1.8 kW & below)	S6-L-M11-3.0	S6-L-M11-5.0	S6-L-M11-10.0	S6-L-B11-3.0	S6-L-B11-5.0	S6-L-B11-10.0
MS1H3 (2.9 kW)	S6-L-M12-3.0	S6-L-M12-5.0	S6-L-M12-10.0	S6-L-B12-3.0	S6-L-B12-5.0	S6-L-B12-10.0
MS1H3 (above 2.9 kW)	S6-L-M22-3.0	S6-L-M22-5.0	S6-L-M22-10.0	S6-L-B22-3.0	S6-L-B22-5.0	S6-L-B22-10.0

## Motor Encoder Cable Item Codes

Model	Servo motor encoder cable- Cable direction toward front side					
	23-bit incremental encoder			23-bit absolute encoder		
	L = 3.0 m	L = 5.0 m	L = 10.0 m	L = 3.0 m	L = 5.0 m	L = 10.0 m
MS1H1	S6-L-P014-3.0	S6-L-P014-5.0	S6-L-P014-10.0	S6-L-P024-3.0	S6-L-P024-5.0	S6-L-P024-10.0
MS1H4	S6-L-P014-3.0	S6-L-P014-5.0	S6-L-P014-10.0	S6-L-P024-3.0	S6-L-P024-5.0	S6-L-P024-10.0

Model	Servo motor encoder cable- Cable direction toward back side					
	23-bit incremental encoder			23-bit absolute encoder		
	L = 3.0 m	L = 5.0 m	L = 10.0 m	L = 3.0 m	L = 5.0 m	L = 10.0 m
MS1H1	S6-L-P015-3.0	S6-L-P015-5.0	S6-L-P015-10.0	S6-L-P025-3.0	S6-L-P025-5.0	S6-L-P025-10.0
MS1H4	S6-L-P015-3.0	S6-L-P015-5.0	S6-L-P015-10.0	S6-L-P025-3.0	S6-L-P025-5.0	S6-L-P025-10.0

Model	Servo motor encoder cable					
	20-bit incremental encoder			23-bit absolute encoder		
	L = 3.0 m	L = 5.0 m	L = 10.0 m	L = 3.0 m	L = 5.0 m	L = 10.0 m
MS1H2	S6-L-P01-3.0	S6-L-P01-5.0	S6-L-P01-10.0	S6-L-P21-3.0	S6-L-P21-5.0	S6-L-P21-10.0
MS1H3 (1.8 kW & below)	S6-L-P01-3.0	S6-L-P01-5.0	S6-L-P01-10.0	S6-L-P21-3.0	S6-L-P21-5.0	S6-L-P21-10.0
MS1H3 (2.9 kW)	S6-L-P01-3.0	S6-L-P01-5.0	S6-L-P01-10.0	S6-L-P21-3.0	S6-L-P21-5.0	S6-L-P21-10.0
MS1H3 (above 2.9 kW)	S6-L-P01-3.0	S6-L-P01-5.0	S6-L-P01-10.0	S6-L-P21-3.0	S6-L-P21-5.0	S6-L-P21-10.0

Model	Connector kit	Battery set for absolute encoder back-up
MS1H2	S6-C2 (CN1 & CN2 terminal, 20-18 pin & 20-29 pin connector)	S6-C4 (Battery & battery case)
MS1H3 (1.8 kW & below)	S6-C2 (CN1 & CN2 terminal, 20-18 pin & 20-29 pin connector)	
MS1H3 (2.9 kW)	S6-C3 (CN1 & CN2 terminal, 20-22 pin & 20-29 pin connector)	
MS1H3 (above 2.9 kW)		

## Appearance of Cables

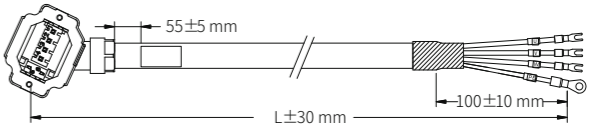
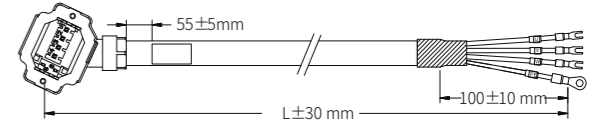
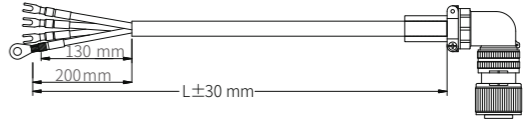
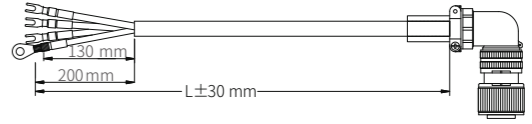
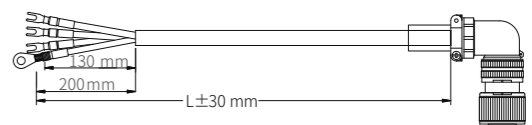
Cable type	Item code	L (mm)	Appearance
Motor power cable- Cable direction towards front	S6-L-M007-3.0	3,000	
	S6-L-M007-5.0	5,000	
	S6-L-M007-10.0	10,000	
Motor power cable- Cable direction towards back	S6-L-M008-3.0	3,000	
	S6-L-M008-5.0	5,000	
	S6-L-M008-10.0	10,000	
Motor power cable	S6-L-M11-3.0	3,000	
	S6-L-M11-5.0	5,000	
	S6-L-M11-10.0	10,000	
	S6-L-M12-3.0	3,000	
	S6-L-M12-5.0	5,000	
	S6-L-M12-10.0	10,000	
	S6-L-M22-3.0	3,000	
	S6-L-M22-5.0	5,000	
	S6-L-M22-10.0	10,000	



# Appearance of Cables

Cable type	Item code	L (mm)	Appearance
Motor brake power cable- Cable direction towards front	S6-L-B007-3.0	3,000	
	S6-L-B007-5.0	5,000	
	S6-L-B007-10.0	10,000	
Motor brake power cable- Cable direction towards back	S6-L-B008-3.0	3,000	
	S6-L-B008-5.0	5,000	
	S6-L-B008-10.0	10,000	
Motor brake power cable	S6-L-B11-3.0	3,000	
	S6-L-B11-5.0	5,000	
	S6-L-B11-10.0	10,000	
Motor encoder cable- Cable direction towards front 23bit incremental encoder (MS1 encoder cable)	S6-L-P014-3.0	3,000	
	S6-L-P014-5.0	5,000	
	S6-L-P014-10.0	10,000	
Motor encoder cable- Cable direction towards back 23bit incremental encoder (MS1 encoder cable)	S6-L-P015-3.0	3,000	
	S6-L-P015-5.0	5,000	
	S6-L-P015-10.0	10,000	
Servo motor 20/23 bit Incremental encoder (H2 / H3 encoder cable)	S6-L-P01-3.0	3,000	
	S6-L-P01-5.0	5,000	
	S6-L-P01-10.0	10,000	
Motor encoder cable- Cable direction towards front 23-bit absolute encoder (MS1 encoder cable)	S6-L-P024-3.0	3,000	
	S6-L-P024-5.0	5,000	
	S6-L-P024-10.0	10,000	
Motor encoder cable- Cable direction towards back 23-bit absolute encoder (MS1 encoder cable)	S6-L-P025-3.0	3,000	
	S6-L-P025-5.0	5,000	
	S6-L-P025-10.0	10,000	

Cable type	Item code	L (mm)	Appearance
Servo motor 20/23 bit Incremental encoder (H2 / H3 encoder cable)	S6-L-P21-3.0	3,000	
	S6-L-P21-5.0	5,000	
	S6-L-P21-10.0	1,000	
IS620P servo drive to PC communication cable	S6-L-T01-3.0	3,000	
IS620P servo drive CAN and RS485 multi-axis communication cable	S6-L-T01-0.3	300	
PLC ↔ IS620P servo drive CAN & RS485 communication cable	S6-L-T02-2.0	2,000	
IS620P Servo drive CAN & RS485 termination resistor	S6-L-T03-0.0		
IS620P Servo drive analog output (CN5) cable	S5-L-A01-1.0	1,000	
IS620N Servo drive EtherCAT communication cable	S6-L-T04-0.3	300	
	S6-L-T04-3.0	3,000	
IS620N Servo drive to PC communication cable	S6N-L-T00-3.0	3,000	
Absolute encoder battery	S6-C4		
Switch cable (When replacing MS1 with old ISMH1 / ISMH4)	S6-C23	500	
IS620 Servo Drive CN1 connector	S6-C8 (DB44)		

# IS620 Servo Drive and Motor Selection Table

Power supply voltage	Motor frame size (mm)	Motor power (W)	Motor rated speed (RPM)	Motor rated torque (Nm)	Motor peak torque (Nm)	Motor brake	IS620 drive H x W x D (mm)	Motor model	IS620P pulse/analog drive	IS620N EtherCAT drive
Single-phase 220V	40	50	3,000	0.16	0.56		160 x 50 x 173	MS1H1-05B30CB-A330Z-INT MS1H1-05B30CB-U330Z-INT	IS620PS1R6I-INT	IS620NS1R6I-INT
		50		0.16	0.56	Brake		MS1H1-05B30CB-A332Z-INT MS1H1-05B30CB-U332Z-INT		
		100		0.32	1.12			MS1H1-10B30CB-A330Z-INT MS1H1-10B30CB-U330Z-INT		
		100		0.32	1.12	Brake		MS1H1-10B30CB-A332Z-INT MS1H1-10B30CB-U332Z-INT		
	60	200		0.64	2.24			MS1H1-20B30CB-A331Z-INT MS1H1-20B30CB-U331Z-INT		
		200		0.64	2.24	Brake		MS1H1-20B30CB-A334Z-INT MS1H1-20B30CB-U334Z-INT		
		400		1.27	4.46			MS1H1-40B30CB-A331Z-INT MS1H1-40B30CB-U331Z-INT		
		400		1.27	4.46	Brake		MS1H1-40B30CB-A334Z-INT MS1H1-40B30CB-U334Z-INT		
	60	400		1.27	4.46			MS1H4-40B30CB-A331Z-INT MS1H4-40B30CB-U331Z-INT		
		400		1.27	4.46	Brake		MS1H4-40B30CB-A334Z-INT MS1H4-40B30CB-U334Z-INT		
		400		1.27	4.46			MS1H4-40B30CB-A331Z-INT MS1H4-40B30CB-U331Z-INT		
		400		1.27	4.46	Brake		MS1H4-40B30CB-A334Z-INT MS1H4-40B30CB-U334Z-INT		
Single-phase & Three-phase 220V	80	550	3,000	1.75	6.13		160 x 50 x 173	MS1H1-55B30CB-A331Z-INT MS1H1-55B30CB-U331Z-INT	IS620PS5R5I-INT	IS620NS5R5I-INT
		750		2.39	8.36			MS1H1-75B30CB-A331Z-INT MS1H1-75B30CB-U331Z-INT		
		750		2.39	8.36	Brake		MS1H1-75B30CB-A334Z-INT MS1H1-75B30CB-U334Z-INT		
		750		2.39	8.36			MS1H4-75B30CB-A331Z-INT MS1H4-75B30CB-U331Z-INT		
		750		2.39	8.36	Brake		MS1H4-75B30CB-A334Z-INT MS1H4-75B30CB-U334Z-INT		
		750		2.39	8.36	Brake		MS1H4-75B30CB-A334Z-INT MS1H4-75B30CB-U334Z-INT		
Three-phase 220V	130	850	1,500	5.39	13.5		160 x 90 x 183	MS1H3-85B15CB-A331Z-INT MS1H3-85B15CB-U331Z-INT	IS620PS7R6I-INT	IS620NS7R6I-INT
		850		5.39	13.5	Brake		MS1H3-85B15CB-A334Z-INT MS1H3-85B15CB-U334Z-INT		
		1,300		8.34	20.85			MS1H3-13B15CB-A331Z-INT MS1H3-13B15CB-U331Z-INT		
		1,300		8.34	20.85	Brake		MS1H3-13B15CB-A334Z-INT MS1H3-13B15CB-U334Z-INT		
Three-phase 220V	80	1,000	3,000	3.18	11.1		160 x 90 x 183	MS1H1-10C30CB-A331Z-INT MS1H1-10C30CB-U331Z-INT	IS620PS7R6I-INT	IS620NS7R6I-INT
		1,000		3.18	7.21			MS1H2-10C30CB-A331Y-INT MS1H2-10C30CB-U231Y-INT		
		1,000		3.18	7.21	Brake		MS1H2-10C30CB-A334Y-INT MS1H2-10C30CB-U234Y-INT		
		1,000		3.18	9.54			MS1H2-10C30CB-A331Y-INT MS1H2-10C30CB-U231Y-INT		
	100	1,000		3.18	9.54	Brake		MS1H2-10C30CB-A334Y-INT MS1H2-10C30CB-U234Y-INT		
		1,500		4.9	12.70			MS1H2-15C30CB-A331Y-INT MS1H2-15C30CB-U231Y-INT		
		1,500		4.9	12.70	Brake		MS1H2-15C30CB-A334Y-INT MS1H2-15C30CB-U234Y-INT		
		1,500		4.9	12.70	Brake		MS1H2-15C30CB-A334Y-INT MS1H2-15C30CB-U234Y-INT		

Power supply voltage	Motor frame size (mm)	Motor power (W)	Motor rated speed (RPM)	Motor rated torque (Nm)	Motor peak torque (Nm)	Motor brake	IS620 drive H x W x D (mm)	Motor model	IS620P pulse/analog drive	IS620N EtherCAT drive
Three-phase 400 V	130	850	1,500	5.39	13.5		160 x 90 x 183	MS1H3-85B15CD-A331Z-INT MS1H3-85B15CD-U331Z-INT	IS620PT3R5I-INT	IS620NT3R5I-INT
		850		5.39	13.5	Brake		MS1H3-85B15CD-A334Z-INT MS1H3-85B15CD-U334Z-INT		
		1,300		8.34	20.85			MS1H3-13C15CD-A331Z-INT MS1H3-13C15CD-U331Z-INT		
		1,300		8.34	20.85	Brake		MS1H3-13C15CD-A334Z-INT MS1H3-13C15CD-U334Z-INT		
		1,800		11.5	28.75			MS1H3-18C15CD-A331Z-INT MS1H3-18C15CD-U331Z-INT		
		1,800		11.5	28.75	Brake		MS1H3-18C15CD-A334Z-INT MS1H3-18C15CD-U334Z-INT		
	180	2,900		18.6	37.2			MS1H3-29C15CD-A331Z-INT MS1H3-29C15CD-U231Z-INT		
		2,900		18.6	37.2	Brake		MS1H3-29C15CD-A334Z-INT MS1H3-29C15CD-U234Z-INT		
		4,400		28.4	71.1			MS1H3-44C15CD-A331Z-INT MS1H3-44C15CD-U231Z-INT		
		4,400		28.4	71.1	Brake		MS1H3-44C15CD-A334Z-INT MS1H3-44C15CD-U234Z-INT		
		5,500		35	87.6			MS1H3-55C15CD-A331Z-INT MS1H3-55C15CD-U231Z-INT		
		5,500		35	87.6	Brake		MS1H3-55C15CD-A334Z-INT MS1H3-55C15CD-U234Z-INT		
Three-phase 400 V	100	1,000	3,000	3.18	9.54		160 x 90 x 183	MS1H2-10C30CD-A331Y-INT MS1H2-10C30CD-U231Y-INT	IS620PT5R4I-INT	IS620NT5R4I-INT
		1,000		3.18	9.54	Brake		MS1H2-10C30CD-A334Y-INT MS1H2-10C30CD-U234Y-INT		
		1,500		4.9	14.7			MS1H2-15C30CD-A331Y-INT MS1H2-15C30CD-U231Y-INT		
		1,500		4.9	14.7	Brake		MS1H2-15C30CD-A334Y-INT MS1H2-15C30CD-U234Y-INT		
		2,000		6.36	19.1			MS1H2-20C30CD-A331Y-INT MS1H2-20C30CD-U231Y-INT		
		2,000		6.36	19.1	Brake		MS1H2-20C30CD-A334Y-S4-INT MS1H2-20C30CD-U234Y-S4-INT		
	130	2,500		7.96	23.90			MS1H2-25C30CD-A331Y-INT MS1H2-25C30CD-U231Y-INT		
		2,500		7.96	23.90	Brake		MS1H2-25C30CD-A334Y-S4-INT MS1H2-25C30CD-U234Y-S4-INT		
		3,000		9.8	29.4			MS1H2-30C30CD-A331Y-INT MS1H2-30C30CD-U231Y-INT		
		3,000		9.8	29.4	Brake		MS1H2-30C30CD-A334Y-S4-INT MS1H2-30C30CD-U234Y-S4-INT		
		4,000		12.6	37.8			MS1H2-40C30CD-A331Y-INT MS1H2-40C30CD-U231Y-INT		
		4,000		12.6	37.8	Brake		MS1H2-40C30CD-A334Y-S4-INT MS1H2-40C30CD-U234Y-S4-INT		
250 x 100 x 230	5,000	15.8	47.6		MS1H2-50C30CD-A331Y-INT MS1H2-50C30CD-U231Y-INT					
	5,000	15.8	47.6	Brake	MS1H2-50C30CD-A334Y-S4-INT MS1H2-50C30CD-U234Y-S4-INT					